

Gate Driver Follower Unit 2LH03CCZCZ9S

■ Overview

2LH03CCZCZ9S is a parallel drive follower unit used by connecting to 2LH03CCVC29M.

IGBT power modules are compatible with CAB600M33LM3-C.

This document is the data sheet of the follower unit.

Please refer to the data sheet: 2LH03CCVC29M for the leader unit.

■ Features

- Ideal for drive of SiC Power module CAB600M33LM3-C (Wolfspeed)
- Ideal for parallel drive by using with 2LH03CCVC29M.
- Gate voltage : +15.2V/-5V
- Gate resistor : +3.3Ω/-1Ω
- Insulation distance (clearance / creepage) : 8mm/22mm (CTI PLC0)
- Desaturation protection (Combination with the leader unit)
- Soft turn-off function (Combination with the leader unit)
- Reinforced isolation according to IEC 60664-1
- Insulating moistureproof coating

■ Application

Industrial inverter, Power conditioner, Railway etc. ...

This target specification is subject to be changed without notice.

■ Circuit Image

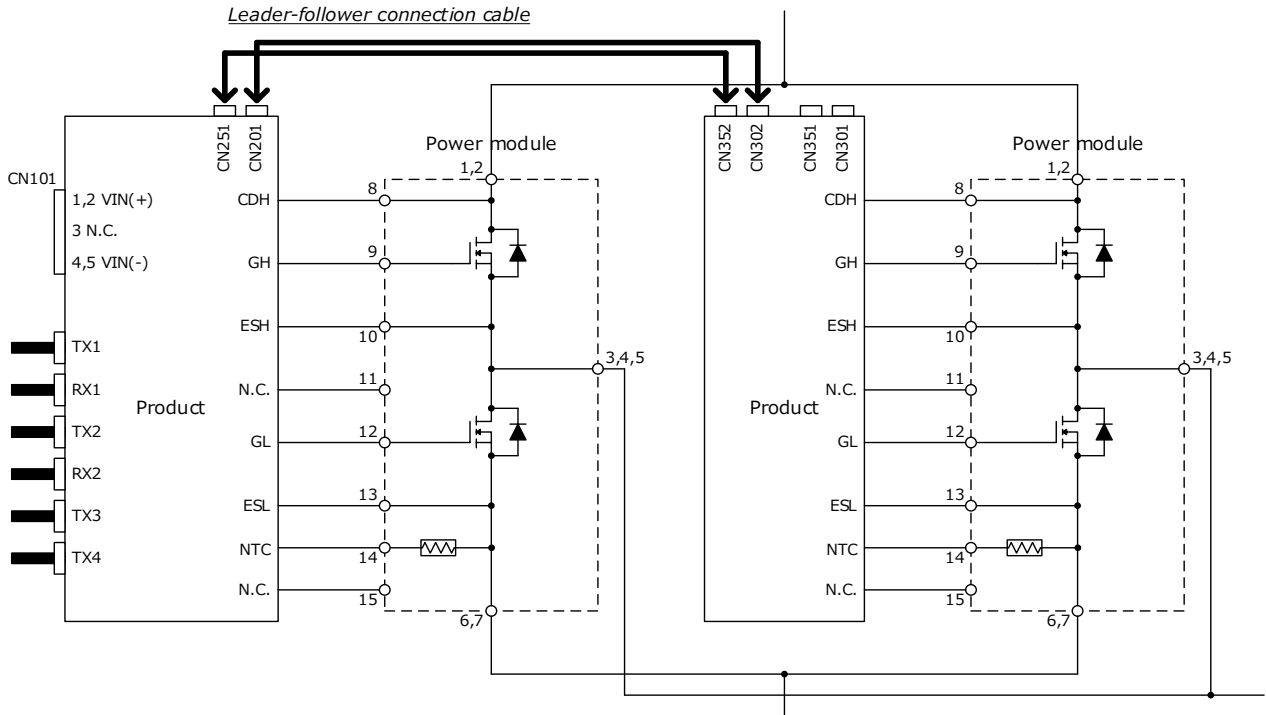

■ I/O sequence

<Nominal>

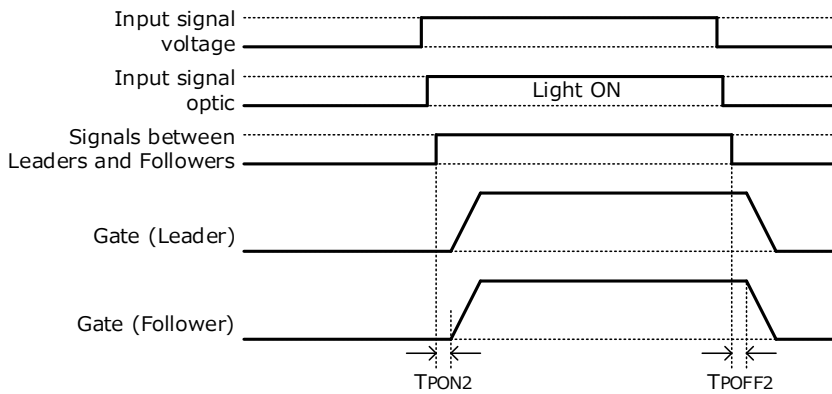

<Desaturation protection>

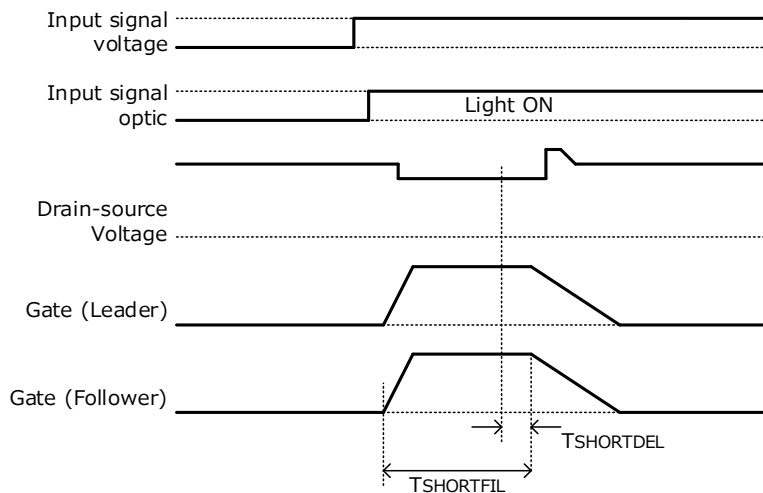

Each unit is equipped with desaturation protection. If even one short circuit is detected, the desaturation protection will be activated.

■ **Interface Description**

- Connector CN301, CN302: Number of circuits = 6 / 5055680681 (Molex)
 Connector for parallel connection of gate driver channel 1 (upper arm)
 ※Reference receptacle : 5055650601 (Molex)

- Connector CN351, CN352: Number of circuits = 8 / 5055680881 (Molex)
 Connector for parallel connection of gate driver channel 2 (lower arm)
 ※Reference receptacle : 5055650801 (Molex)

- Connection on the power module

Pin No.	Name	CH	Function	Pin No.	Name	CH	Function
8	CDH	1(U)	Drain connection, Upper arm	12	GL	2(L)	Gate connection, Lower arm
9	GH	1(U)	Gate connection, Upper arm	13	ESL	2(L)	Source connection, Lower arm
10	ESH	1(U)	Source connection, Upper arm	14	NTC	2(L)	Thermistor connection
11	N.C.	-	Only fixing the printed circuit board	15	N.C.	-	Only fixing the printed circuit board

■ **Internal Block Diagram**

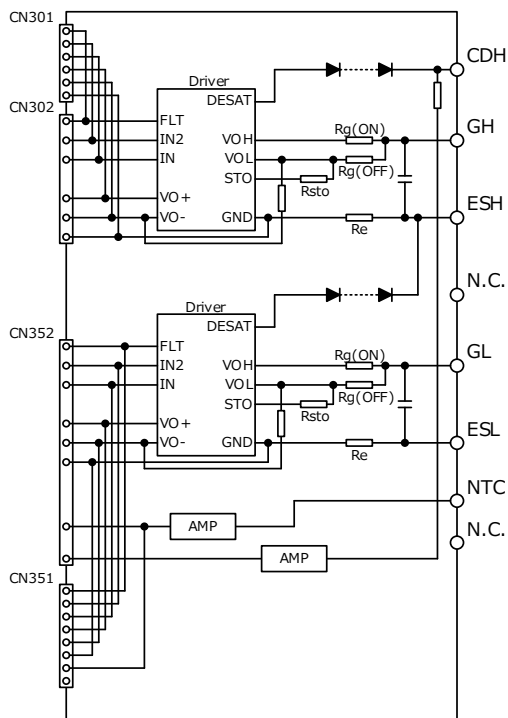

■ Leader-follower connection diagram

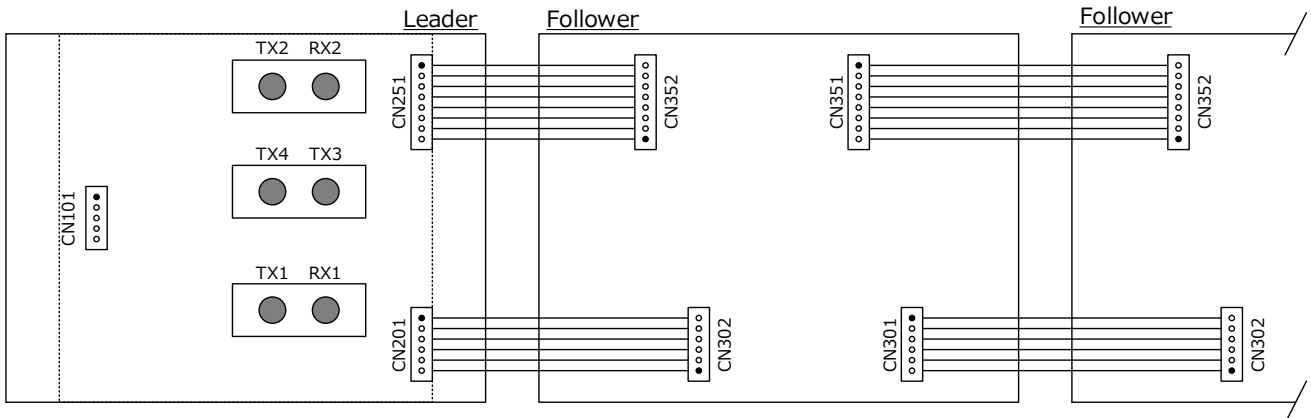

■ Leader-follower connection cable example

*This sample is provided with cable.

*You must meet the required wire standard according to the usage conditions.

<Parallel CN-LEAD for gate driver channel 1 (upper arm)>

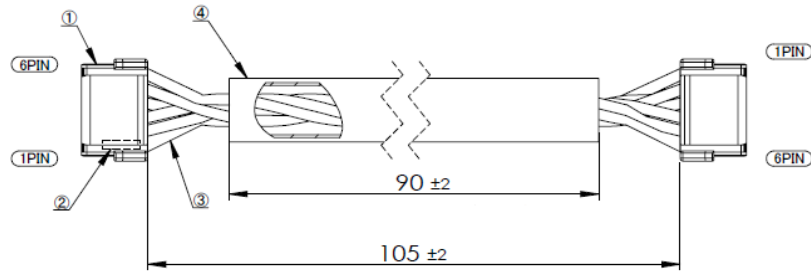

<Parallel CN-LEAD for gate driver channel 2 (lower arm)>

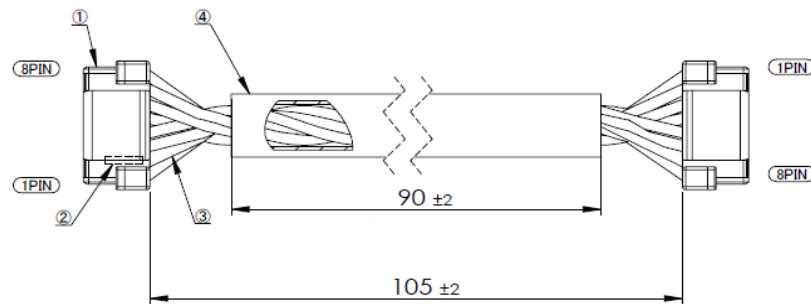

No.	Name	for gate driver channel 1 (upper arm)		for gate driver channel 2 (lower arm)		Manufacturer
		Part No,	Quantity	Part No,	Quantity	
①	Housing	5055650601	2	5055650801	2	MOLEX
②	Contact	5054311100	12	5054311100	16	MOLEX
③	Wire	AWG#26(UL3443) *Twist processing	6	AWG#26(UL3443) *Twist processing	8	-
④	Tube	SUMITUBE F2(Z)	1	SUMITUBE F2(Z)	1	SUMITOMO

■ Absolute Maximum Ratings

Item	Symbol	Min	Max	Unit	Conditions · Note	
Maximum gate current	I_{GPEAK}	-	43	A	Excluding gate resistor	
DC-link voltage	Steady-state	0	2200	V		
	< 60sec	0	2500	V		
Operating temperature range	Ambient	T_{OP}	-40	85	°C	
	Component surface		-40	120	°C	
Operating humidity	RH_{OP}	20	85	%RH	No condensation	
Storage temperature range	T_{STG}	-40	90	°C		
Storage humidity	RH_{STG}	5	95	%RH	No condensation	

■ Recommended Operating Conditions

Item	Symbol	Min	Max	Unit	Conditions · Note
Target Device Drain-source voltage	V_{DSMAX}	-	3300	V	
Driver circuit number	N	-	2	-	
SiC parallel number	N	-	6	-	
Maximum gate charge	Q_G	-	7000	nC	*1
Switching frequency ($Q_g=5120nC$)	F_{SW}	-	8.5	kHz	

*1 If the gate charge exceeds the allowable value, the gate voltage at turn-on and turn-off will drop, which may affect the switching performance of the SiC.

If you are considering using it under conditions other than the recommended conditions, please contact us.

■ Permissible frequency curve

Internal gate resistor of SiC = 0.5Ω

*The permissible frequency curve changes with the ratio of the SiC internal gate resistance to the gate resistance.

Therefore, as the internal resistance of the SiC decreases, the allowable frequency also decreases.

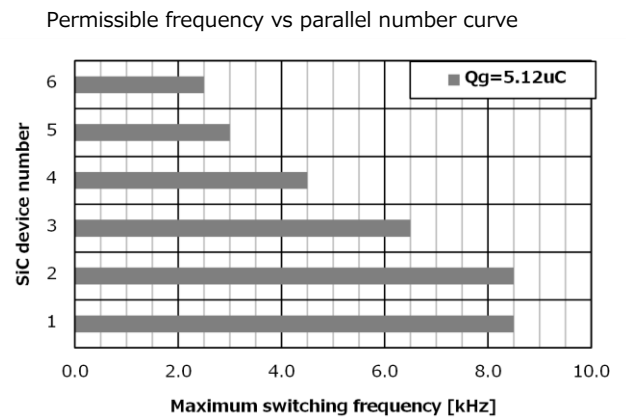
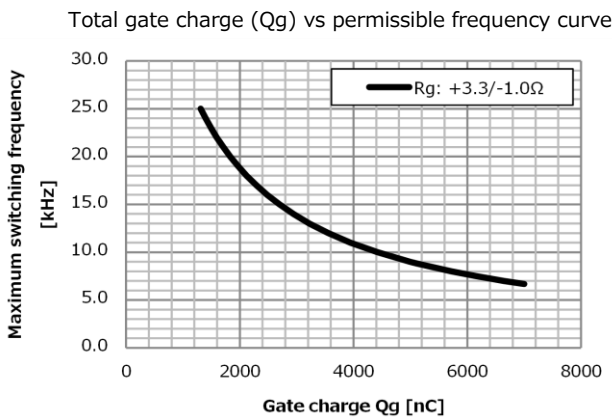

■ Electrical Specification (Vin=15V, Ta=25°C, Unless otherwise specified)

Item	Symbol	Min	Typ	Max	Unit	Conditions · Note	
Gate output							
Gate resistor	Rg(ON)	-	3.3	-	Ω		
	Rg(OFF)	-	1	-			
Emitter resistor	Re	-	0.1	-	Ω		
Auxiliary gate capacitor	Cge	-	33	-	nF		
Delay time *	Turn ON time	t _{PON}	-	55	-	ns	
	Turn OFF time	t _{POFF}	-	45	-	ns	

■ Protection

Item	Symbol	Min	Typ	Max	Unit	Conditions · Note
Gate driver						
Short circuit detection voltage	V _{SD}	-	7.5	-	V	Guaranteed by design
Short circuit detection filter time	t _{SHORTFIL}	-	1.5	-	us	10% to 98% of VGS
Soft turn-off resistance	R _{STO}	-	10	-	Ω	

■ Insulation

Item	Specification	Conditions · Note
Between Output-Output		
Minimum clearance distances	8mm	
Minimum creepage distances	22mm	PCB: CTI PLC0, Case: CTI PLC0

■ Storage Conditions

Item	Min	Max	Unit	Conditions · Note
Storage temperature	-25	60	°C	A packing state

■ Usage Cautions

- Please do not apply excessive stress to this product when attaching to SiC power module.
Please follow the device manufacturer's instructions on how to install the SiC power module (type of screw used, material, tightening torque conditions, etc.).
M3: 6mm or less *To maintain the reliability of parts near the metal terminal pad, the screw header including the washer must not exceed the available metal terminal pad of the gate driver.
- This product has DESAT protection for arm short circuit and load short circuit protection.
However, even if this protection works, the SiC may be damaged if abnormally high current occurs due to SiC's characteristics variations or the load short-circuit mode during parallel operation.
To ensure safety, be sure to check the short-circuit current at the unit in which this product is integrated, and evaluate whether it can protect under the condition that there is no damage to the SiC.
- The coating material is applied to the product, so it may appear to be partially whitened.
This does not affect the characteristics of the product.

■ Outline Dimensional Drawing

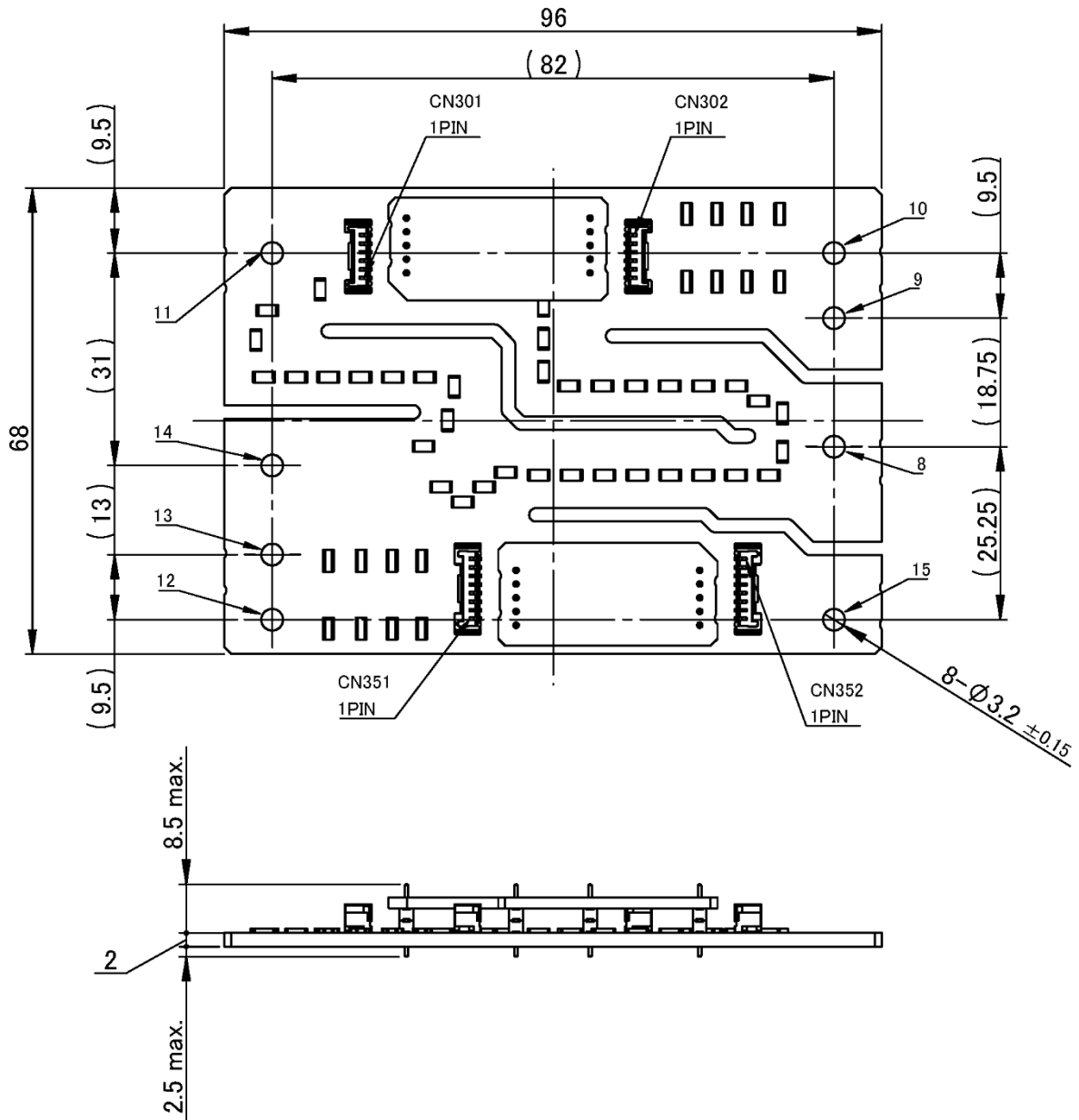

Unit: mm

Note: 1. The dimensional tolerance without directions is ± 0.5 mm.

■ Product Weight

35 g(typ)

■ Important Notice

- This information and product are subject to change without prior notice for the purpose of improvements, etc. Ensure that you are in possession of the most up-to-date information when using this product.
- The operation examples and circuit examples shown in this document are for reference purposes only, and TAMURA Corporation disclaims all responsibility for any violations of industrial property rights, intellectual property rights and any other rights owned by TAMURA Corporation or third parties that these may entail.
- The circuit examples and part constants listed in this document are provided as reference for the verification of characteristics. You are to perform design, verification, and judgment at your own responsibility, taking into account the various conditions.
- TAMURA has evaluated the efficiency and performance of this product in a usage environment determined by us. Depending on your usage environment or usage method, there is the possibility that this product will not perform sufficiently as shown in the specifications, or may malfunction.
When applying this product to your devices or systems, please ensure that you conduct evaluations of their state when integrated with this product. You are responsible for judging its applicability.
TAMURA bears no responsibility whatsoever for any problems with your devices, systems or this product which are caused by your usage environment or usage method.
- TAMURA Corporation constantly strives to improve quality and reliability, but malfunction or failures are bound to occur with some probability in power products. To ensure that failures do not cause accidents resulting in injury or death, fire accidents, social damage, and so on, you are to thoroughly verify the safety of their designs in devices and/or systems, at your own responsibility.
- This product is intended for use in consumer electronics (electric home appliances, business equipment, Information equipment, communication terminal equipment, measuring devices, and so on.) If considering use of this product in equipment or devices that require high reliability (medical devices, transportation equipment, traffic signal control equipment, fire and crime prevention equipment, aeronautics and space devices, nuclear power control, fuel control, in-vehicle equipment, safety devices, and so on), please consult a TAMURA sales representative in advance. Do not use this product for such applications without written permission from TAMURA Corporation.
- This product is intended for use in environments where consumer electronics are commonly used. It is not designed for use in special environments such as listed below, and if such use is considered, you are to perform thorough safety and reliability checks at your own responsibility.
 - Use in liquids such as water, oil, chemical solutions, or organic solvents, and use in locations where the product will be exposed to such liquids.
 - Use that involves exposure to direct sunlight, outdoor exposure, or dusty conditions.
 - Use in locations where corrosive gases such as salt air, C12, H2S, NH3, SO2, or NO2, are present.
 - Use in environments with strong static electricity or electromagnetic radiation.
 - Use that involves placing inflammable material next to the product.
 - Use of this product either sealed with a resin filling or coated with resin.
 - Use of water or a water soluble detergent for flux cleaning.
 - Use in locations where condensation is liable to occur.
- This product is not designed to resist radiation.
- This product is not designed to be connected in series or parallel.
Do not operate this product in a series, parallel, or N+1 redundant configuration.
- Do not use or otherwise make available the TAMURA products or the technology described in this document for any military purposes, including without limitation, for the design, development, use, stockpiling or manufacturing of mass destruction weapons (e.g. nuclear, chemical, or biological weapons or missile technology products).
When exporting and re-exporting the products or technology described in this document, you should comply with the applicable export control laws and regulations and follow the procedures required by such laws and regulations including, without limitation, Japan -Foreign Exchange and Foreign Trade Control Law and U.S.- Export Administration Regulations.
The TAMURA products and related technology should not be used for or incorporated into any products or systems whose manufacture, use, or sale is prohibited under any applicable domestic or foreign laws or regulations.
- Please contact your TAMURA sales office for details as to environmental matters such as the RoHS compatibility of product.
Please use TAMURA products in compliance with all applicable laws and regulations that regulate the inclusion or use of controlled substances, including without limitation, the EU RoHS Directive.
TAMURA assumes no liability for damages or losses occurring as a result of your noncompliance with applicable laws and regulations.
- TAMURA assumes no liability for damages or losses incurred by you or third parties as a result of unauthorized use of TAMURA products.
- This document and any information herein may not be reproduced in whole or in part without prior written permission from TAMURA.