

Gate Driver Unit 2LH03CCVC29M

■ Overview

2LH03CCVC29M is a dual channel gate driver designed for Wolfspeed's SiC power module CAB600M33LM3-C .

This gate driver unit contains a built-in isolated DC/DC converter and gate drive circuit.

It is ready to use by mounting it on the SiC power module.

■ Features

- Ideal for drive of SiC Power module CAB600M33LM3-C (Wolfspeed)
- Gate voltage : +15.2V/-5V
- Gate resistor : +3.3Ω/-1Ω
- Short circuit detection voltage : 7.5V
- ALL-IN-ONE (Built-in isolated DC / DC converter and gate drive circuit)
- Low parasitic capacitance ; highly resistant to common-mode noise.
- Fast response : About 150nsec
- Signal insulation with optical fiber
- Dielectric withstand voltage : AC10.8kV
- DC/DC converter input voltage : 15V, 24V
- The DC / DC converter has built-in overheat protection and overload protection.
- Desaturation protection (Gate drive circuit)
- Soft turn-off function (Gate drive circuit)
- Fault signal output function (Gate drive circuit)
- Under-voltage lockout (UVLO) (Gate drive circuit)
- PWM output function (NTC thermistor temperature inside the device / DC link voltage)
- Reinforced isolation according to IEC 60664-1
- Conformal coating

■ Application

Industrial inverter, Power conditioner, Railway etc. ...

This target specification is subject to be changed without notice.

■ Circuit Image

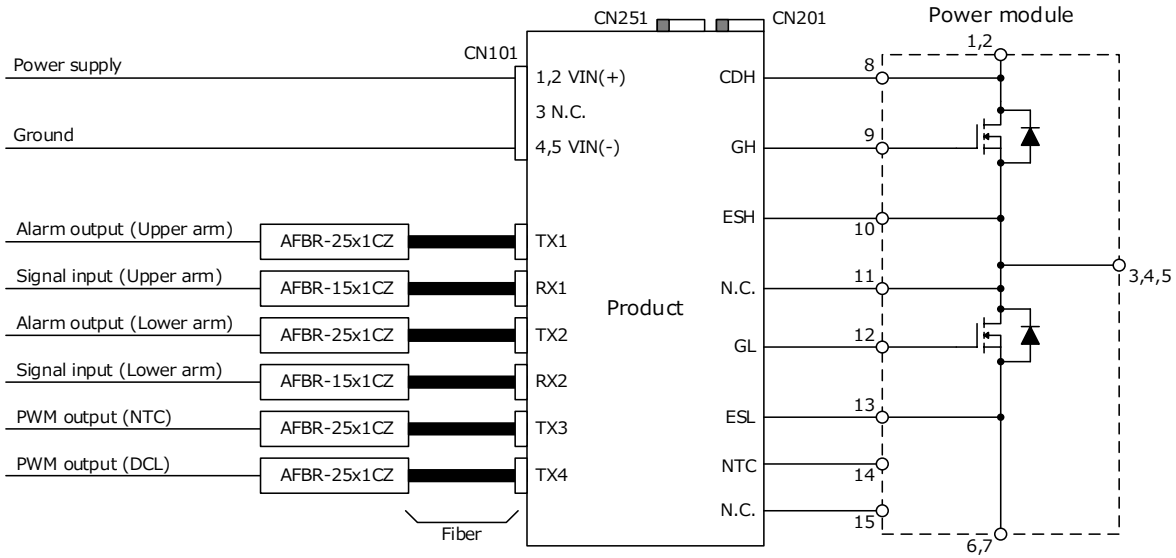

■ I/O sequence

<Nominal>

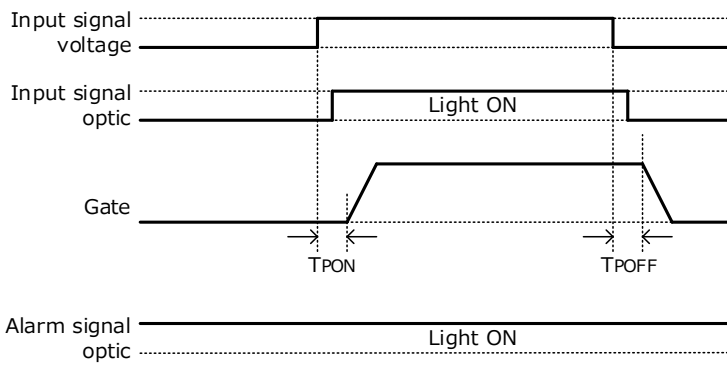

<Desaturation protection>

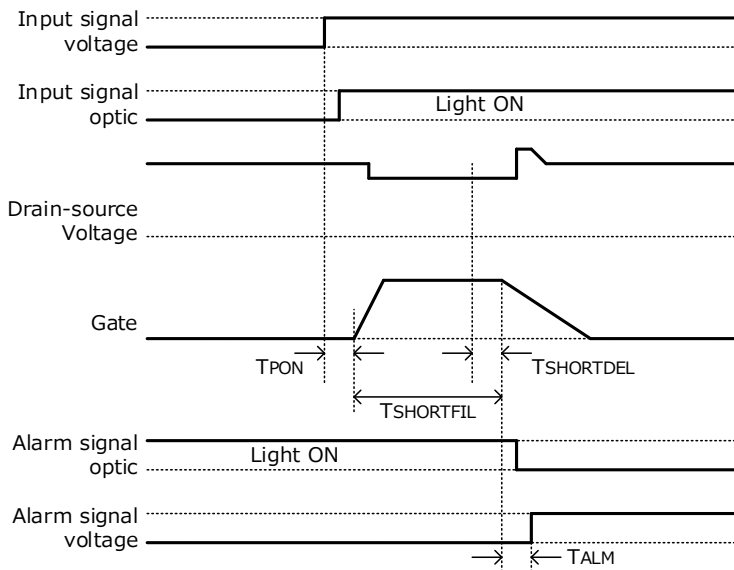

Interface Description

- Connector CN101: 5055670581 (Molex)

For power supply

Pin No.	Name	Function
1	VIN(+)	Power supply for DC/DC converter(+)
2	VIN(+)	Power supply for DC/DC converter(+)
3	N.C.	Not used
4	VIN(-)	Power supply for DC/DC converter(-)
5	VIN(-)	Power supply for DC/DC converter(-)

※Reference receptacle : 5055650501 (Molex)

- Fiber optic receiver RX1: AFBR-2531CZ (Broadcom) *Signaling rate: 5Mbd
Upper arm side gate signal receiver. Recommended transmitter: AFBR-15x1CZ (Broadcom)
- Fiber optic receiver RX2: AFBR-2531CZ (Broadcom) *Signaling rate: 5Mbd
Lower arm side gate signal receiver. Recommended transmitter: AFBR-15x1CZ (Broadcom)
- Fiber optic transmitter TX1: AFBR-1531CZ (Broadcom) *Signaling rate: 5Mbd
Upper arm side alarm signal transmitter. Recommended receiver: AFBR-25x1CZ (Broadcom)
- Fiber optic transmitter TX2: AFBR-1531CZ (Broadcom) *Signaling rate: 5Mbd
Lower arm side alarm signal transmitter. Recommended receiver: AFBR-25x1CZ (Broadcom)
- Fiber optic transmitter TX3: AFBR-1531CZ (Broadcom) *Signaling rate: 5Mbd
Transmitter that outputs the measured temperature of the NTC thermistor by PWM.
When driving in parallel, the data of the device with the highest temperature is sent.
Recommended receiver: AFBR-25x1CZ (Broadcom)
- Fiber optic transmitter TX4: AFBR-1531CZ (Broadcom) *Signaling rate: 5Mbd
Transmitter that outputs the measured DC-link voltage by PWM.
Recommended receiver: AFBR-25x1CZ (Broadcom)
- Connector CN201: Number of circuits = 6
Connector connection from master unit to slave unit for gate driver channel 1 (Upper arm)
- Connector CN251: Number of circuits = 8
Connector connection from master unit to slave unit for gate driver channel 2 (Lower arm)
- Connection on the power module

Pin No.	Name	CH	Function	Pin No.	Name	CH	Function
8	CDH	1(U)	Drain connection, Upper arm	12	GL	2(L)	Gate connection, Lower arm
9	GH	1(U)	Gate connection, Upper arm	13	ESL	2(L)	Source connection, Lower arm
10	ESH	1(U)	Source connection, Upper arm	14	NTC	2(L)	Thermistor connection
11	N.C.	-	Only fixing the printed circuit board	15	N.C.	-	Only fixing the printed circuit board

Internal Block Diagram

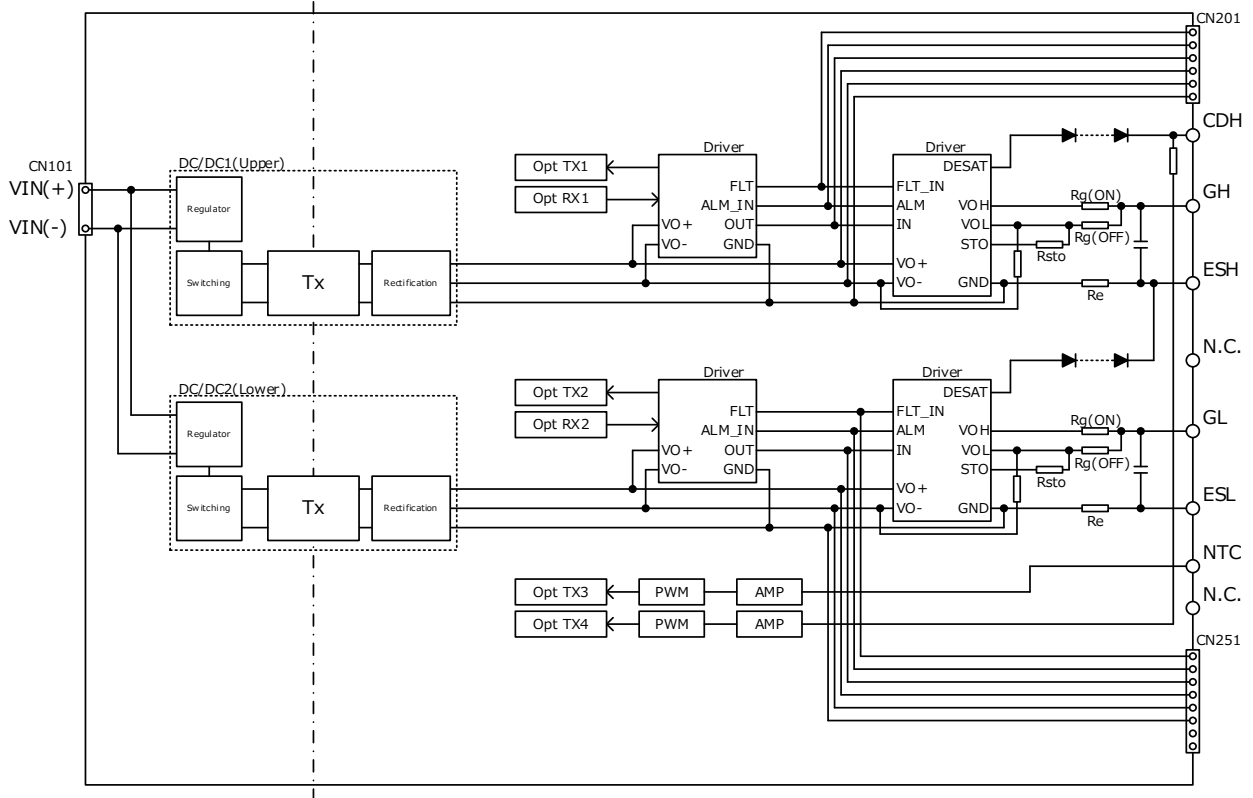

■ Absolute Maximum Ratings

Item	Symbol	Min	Max	Unit	Conditions · Note
Input voltage for DC/DC converter	V _{IN}	-0.3	26.4	Vdc	Between VIN(+) to VIN(-)
Maximum gate resistor loss per CH	P _{rg}	-	0.9	W	Ta=85°C
Maximum output power per CH	P _{out}	-	2.8	W	Ta=85°C, Including gate driver internal loss
Maximum gate current	I _{GPEAK}	-	43	A	Excluding gate resistor
Switching frequency	F _{SW}	-	25	kHz	See the permissible frequency curve
DC-link voltage	Steady-state	0	2200	V	
	< 60sec	0	2500	V	
Operating temperature range	Ambient	T _{OP}	-40	85	°C
	Component surface		-40	120	°C
Operating humidity	RH _{OP}	20	85	%RH	No condensation
Storage temperature range	T _{STG}	-40	90	°C	
Storage humidity	RH _{STG}	5	85	%RH	No condensation

■ Recommended Operating Conditions

Item	Symbol	Min	Max	Unit	Conditions · Note
Target Device Drain-source voltage	V _{DSMAX}	-	3300	V	
Input voltage range for DC/DC converter	V _{IN}	14.25	25.2	Vdc	
Driver circuit number	N	-	2	-	
SiC parallel number	N	-	6	-	
Maximum gate charge	Q _G	-	7000	nC	*1
Switching frequency (Qg=5120nC)	F _{SW}	-	8.5	kHz	

*1 If the gate charge exceeds the allowable value, the gate voltage at turn-on and turn-off will drop, which may affect the switching performance of the SiC.

If you are considering using it under conditions other than the recommended conditions, please contact us.

■ I/O Condition Table

No.	Status	Input					Output			
		OUT(H)	CDH	ESH	RX1	RX2	TX1	TX2	GH	GL
1	V _{OUT} UVLO	UVLO	X	X	X	X	H	H	L	L
2	G-S short	○	X	X	X	X	H	H	SD	SD
3	Normal operation	○	-	L	-	L	-	L	-	L
4		○	-	L	-	H	-	L	-	H
5		○	L	-	L	-	L	-	L	-
6		○	L	-	H	-	L	-	H	-
7	Short circuit detection (L)	○	-	H	-	L	-	L	-	L
8		○	-	H	-	H	-	H	-	L
9	Short circuit detection (H)	○	H	-	L	-	L	-	L	-
10		○	H	-	H	-	H	-	L	-

G-S short : Gate-Source short

○ : OUT(H) > UVLO, X : Don't care

SD : Shut down (Gate-Source short)

RX1,2:

Status L: The transmitting side has without current.

Status H: The transmitting side is with current.

TX1,2:

Status L: With optical signal.

Status H: Without optical signal.

■ Permissible frequency curve

Internal gate resistor of SiC = 0.5Ω

*The permissible frequency curve changes with the ratio of the SiC internal gate resistance to the gate resistance.

Therefore, as the internal resistance of the SiC decreases, the allowable frequency also decreases.

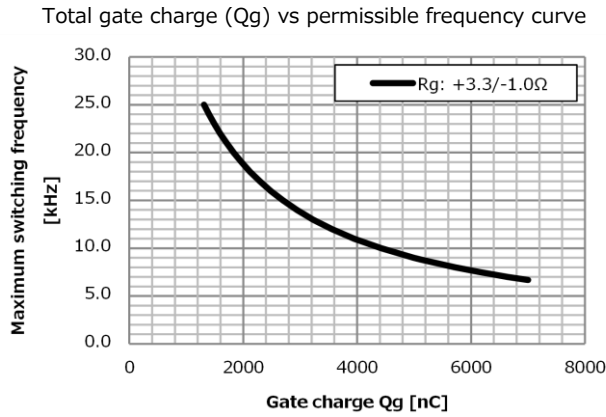

■ Electrical Specification (Vin=15V, Ta=25°C, Unless otherwise specified)

Item	Symbol	Min	Typ	Max	Unit	Conditions · Note	
Power supply							
Start-up voltage	V _{START}	-	-	13	V		
Input current	I _{IN}	-	0.3	-	A	Fsw=8.5kHz, Test load : 256nF	
		-	0.56	-		Fsw=0kHz, Io=140mA	
		-	0.3	-		Fsw=12kHz, Test load : 180nF	
Standby power	P _{STBY}	-	2	-	W	Without load	
Gate output							
Gate turn on voltage	V _{GEON}	14.2	15.2	16.2	V	Without load	
Gate turn off voltage	V _{GEOFF}	-7	-5	-4	V	Without load	
	V _{GEOFF}	-5.5	-4.5	-3.5	V	With load Io=140mA	
Gate resistor	Rg(ON)	-	3.3	-	Ω		
	Rg(OFF)	-	1	-			
Source resistor	Re	-	0.1	-	Ω		
Auxiliary gate capacitor	Cge	-	33	-	nF		
Delay time	Turn ON time	t _{PON}	-	150	-	ns	
	Turn OFF time	t _{POFF}	-	140	-	ns	
Optic fiber							
Transmitter peak output power	Pt	-	-6	-	dBm	AFBR-15x1CZ, I _F =10mA	

Optical digital output (Ta=25°C, Unless otherwise specified)

Item	Symbol	Min	Typ	Max	Unit	Conditions · Note
NTC temperature optical output						
Carrier frequency	-	-	10	-	kHz	
Duty cycle	-	-	5	-	%	Tntc ≤ 20°C, Rntc ≥ 6065Ω *
	-	-	95	-	%	Tntc ≥ 150°C, Rntc ≤ 176Ω *
Filter time	-	-	10	-	ms	Analog filter, 3τ / 95%
DC-link voltage optical output						
Carrier frequency	-	-	10	-	kHz	
Duty cycle	-	-	5	-	%	V _{DC-Link} = 0V
	-	-	95	-	%	V _{DC-Link} ≥ 2880V
Filter time	-	-	1	-	ms	Analog filter, 3τ / 95%

*NTC condition: R₂₅ = 5kΩ, B_(25/50) = 3375K

Duty cycle vs NTC resistance

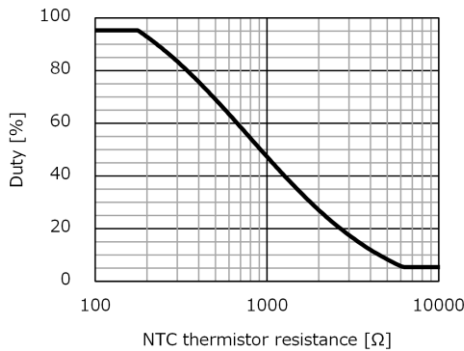

Duty cycle vs NTC temperature (Reference)

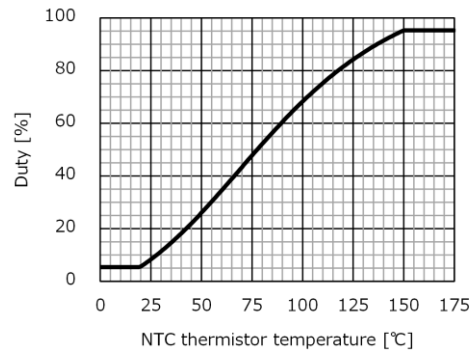

Duty cycle vs DC-Link voltage

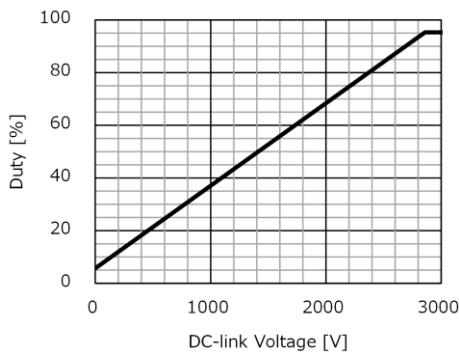

Circuit example

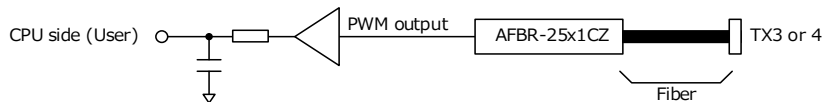

I/O sequence

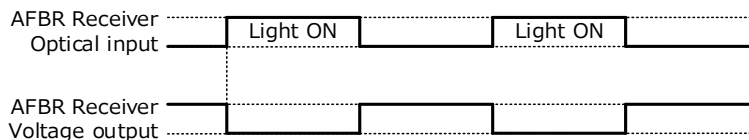

■ Protection

Item	Symbol	Min	Typ	Max	Unit	Conditions · Note
DC/DC converter						
Overcurrent protection	-	0.3	-	-	A	Auto recovery
Overheat protection	-	120	-	-	°C	Auto recovery, Internal temperature
Gate driver						
Output voltage(H) UVLO OFF voltage	V _{UVLOOFFH}	-	13.5	-	V	Guaranteed by design
Output voltage(H) UVLO ON voltage	V _{UVLOOHL}	-	12.5	-	V	Guaranteed by design
Short circuit detection voltage	V _{SD}	-	7.5	-	V	Guaranteed by design
Short circuit detection filter time	t _{SHORTFIL}	-	1.5	-	us	10% to 98% of VGS
Alarm signal output time	t _{ALM}	-	0.1	-	us	Guaranteed by design
Restart time	t _{RESTART}	-	25	-	ms	
Soft turn-off resistance	R _{STO}	-	10	-	Ω	

■ Insulation

Item	Specification	Conditions · Note
Between Input-Output		
Dielectric withstand voltage	AC10.8kV	60sec, type test only
Dielectric withstand voltage (Routine test)	AC5.6kV	10sec, Cutoff 2mA
Insulation resistance	100MΩ or more	DC500V
Partial discharge extinction voltage	4.95kV _{peak} or more	According to EN50178/IEC 60270
Common-mode transient immunity (CMTI)	70kV/us	
Minimum clearance distances	23.8mm (Outside of the filling)	
	15.1mm (Inside of the filling)*1 *2	
Minimum creepage distances	45mm (Outside of the filling)	PCB: CTI PLC0, Case: CTI PLC0
	15.1mm (Inside of the filling)*1 *2	
Between Output-Output		
Minimum clearance distances	8mm	
Minimum creepage distances	22mm	PCB: CTI PLC0, Case: CTI PLC0

*1 The inside of the filling assumes PD1.

*2 Regarding the inside of the filling, type 2 protection or solid insulation may be applicable depending on the standard. Please contact us.

■ Storage Conditions

Item	Min	Max	Unit	Conditions · Note
Storage temperature	-25	60	°C	A packing state

■ Usage Cautions

- Always mount fuse on the plus side of input for ensuring safety because the fuse is not built-in the product.
Please select the fuse considering conditions such as steady current, inrush current, and ambient temperature.
When using a fuse having large rated current or high capacity input electrolytic condenser, by combining another converter and input line and input electrolytic condenser, fuse may not blow off in the case of abnormality.
Do not combine high voltage line and fuse.
- Please do not apply excessive stress to this product when attaching to SiC power module.
Please follow the device manufacturer's instructions on how to install the SiC power module (type of screw used, material, tightening torque conditions, etc.).
M3: 6mm or less *To maintain the reliability of parts near the metal terminal pad, the screw header including the washer must not exceed the available metal terminal pad of the gate driver.
- This product has DESAT protection for arm short circuit and load short circuit protection.
However, even if this protection works, the SiC may be damaged if abnormally high current occurs due to SiC's characteristics variations or the load short-circuit mode during parallel operation.
To ensure safety, be sure to check the short-circuit current at the unit in which this product is integrated, and evaluate whether it can protect under the condition that there is no damage to the SiC.
- The coating material is applied to the product, so it may appear to be partially whitened.
This does not affect the characteristics of the product.

■ Outline Dimensional Drawing

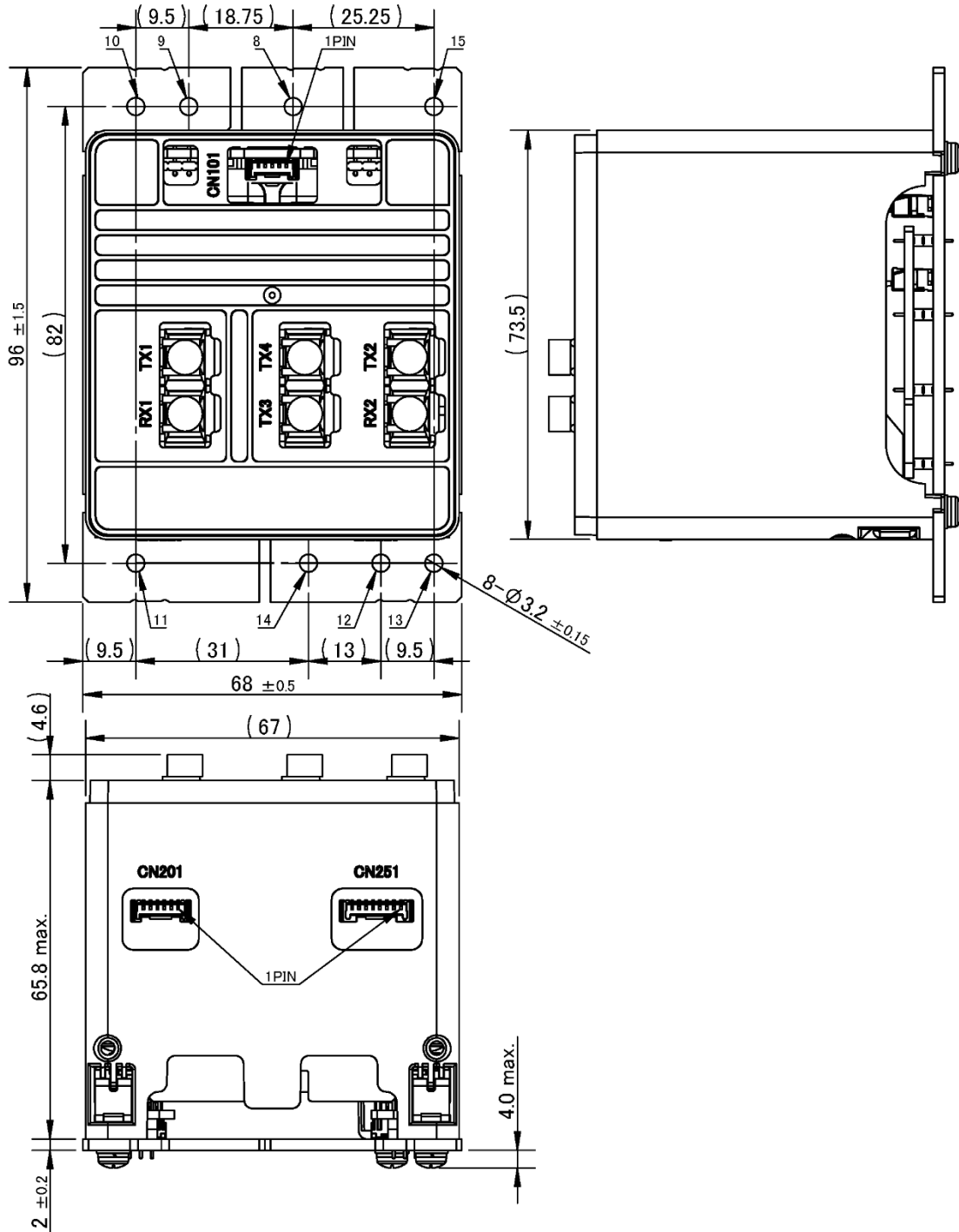

Unit: mm

Note: 1. The dimensional tolerance without directions is ± 0.5 mm.

■ Product Weight

T.B.C g(typ)

■ Important Notice

- This information and product are subject to change without prior notice for the purpose of improvements, etc. Ensure that you are in possession of the most up-to-date information when using this product.
- The operation examples and circuit examples shown in this document are for reference purposes only, and TAMURA Corporation disclaims all responsibility for any violations of industrial property rights, intellectual property rights and any other rights owned by TAMURA Corporation or third parties that these may entail.
- The circuit examples and part constants listed in this document are provided as reference for the verification of characteristics. You are to perform design, verification, and judgment at your own responsibility, taking into account the various conditions.
- TAMURA has evaluated the efficiency and performance of this product in a usage environment determined by us. Depending on your usage environment or usage method, there is the possibility that this product will not perform sufficiently as shown in the specifications, or may malfunction.
When applying this product to your devices or systems, please ensure that you conduct evaluations of their state when integrated with this product. You are responsible for judging its applicability.
TAMURA bears no responsibility whatsoever for any problems with your devices, systems or this product which are caused by your usage environment or usage method.
- TAMURA Corporation constantly strives to improve quality and reliability, but malfunction or failures are bound to occur with some probability in power products. To ensure that failures do not cause accidents resulting in injury or death, fire accidents, social damage, and so on, you are to thoroughly verify the safety of their designs in devices and/or systems, at your own responsibility.
- This product is intended for use in consumer electronics (electric home appliances, business equipment, Information equipment, communication terminal equipment, measuring devices, and so on.) If considering use of this product in equipment or devices that require high reliability (medical devices, transportation equipment, traffic signal control equipment, fire and crime prevention equipment, aeronautics and space devices, nuclear power control, fuel control, in-vehicle equipment, safety devices, and so on), please consult a TAMURA sales representative in advance. Do not use this product for such applications without written permission from TAMURA Corporation.
- This product is intended for use in environments where consumer electronics are commonly used. It is not designed for use in special environments such as listed below, and if such use is considered, you are to perform thorough safety and reliability checks at your own responsibility.
 - Use in liquids such as water, oil, chemical solutions, or organic solvents, and use in locations where the product will be exposed to such liquids.
 - Use that involves exposure to direct sunlight, outdoor exposure, or dusty conditions.
 - Use in locations where corrosive gases such as salt air, C12, H2S, NH3, SO2, or NO2, are present.
 - Use in environments with strong static electricity or electromagnetic radiation.
 - Use that involves placing inflammable material next to the product.
 - Use of this product either sealed with a resin filling or coated with resin.
 - Use of water or a water soluble detergent for flux cleaning.
 - Use in locations where condensation is liable to occur.
- This product is not designed to resist radiation.
- This product is not designed to be connected in series or parallel.
Do not operate this product in a series, parallel, or N+1 redundant configuration.
- Do not use or otherwise make available the TAMURA products or the technology described in this document for any military purposes, including without limitation, for the design, development, use, stockpiling or manufacturing of mass destruction weapons (e.g. nuclear, chemical, or biological weapons or missile technology products).
When exporting and re-exporting the products or technology described in this document, you should comply with the applicable export control laws and regulations and follow the procedures required by such laws and regulations including, without limitation, Japan -Foreign Exchange and Foreign Trade Control Law and U.S.- Export Administration Regulations.
The TAMURA products and related technology should not be used for or incorporated into any products or systems whose manufacture, use, or sale is prohibited under any applicable domestic or foreign laws or regulations.
- Please contact your TAMURA sales office for details as to environmental matters such as the RoHS compatibility of product.
Please use TAMURA products in compliance with all applicable laws and regulations that regulate the inclusion or use of controlled substances, including without limitation, the EU RoHS Directive.
TAMURA assumes no liability for damages or losses occurring as a result of your noncompliance with applicable laws and regulations.
- TAMURA assumes no liability for damages or losses incurred by you or third parties as a result of unauthorized use of TAMURA products.
- This document and any information herein may not be reproduced in whole or in part without prior written permission from TAMURA.