

■ Overview

This document is the application notes about the design of 2LG series.

The example of application circuits and parts value which are indicated to this application note aim at assistance of a design.

Therefore, external parts variation or user operating conditions are not fully taken into consideration.

Please take parts variation, operating conditions into consideration when designing.

Contents

1. Application Examples -----	2
1.1 Direct mode / No thermistor isolated amplifier output function -----	2
1.2 Half bridge mode / No thermistor isolated amplifier output function -----	2
1.3 Direct mode / With thermistor isolated amplifier output function -----	3
1.4 Half bridge mode / With thermistor isolated amplifier output function -----	3
1.5 Direct mode / With thermistor PWM output function -----	4
1.6 Half bridge mode / With thermistor PWM output function -----	4
2. Pin Functions and Descriptions -----	5
2.1 Pin Functions -----	5
2.2 Description -----	7
3. Product Connection Instructions, Ambient Environment Instructions, Usage Cautions -----	9
3.1 Abnormal input current protection -----	9
3.2 VIN- and GND -----	9
3.3 Power ON / OFF sequence (VIN+, VCC) -----	9
3.4 Mechanical switch -----	9
3.5 Input signals -----	10
3.6 Input cables -----	10
3.7 Half bridge mode -----	10
3.8 Product mounting instructions -----	11
3.9 Handling -----	12
3.10 IGBT/SiC MOSEFT short circuit -----	12
3.11 Ambient temperature instructions -----	12

1. Application Examples

1.1 Direct mode / No thermistor isolated amplifier output function

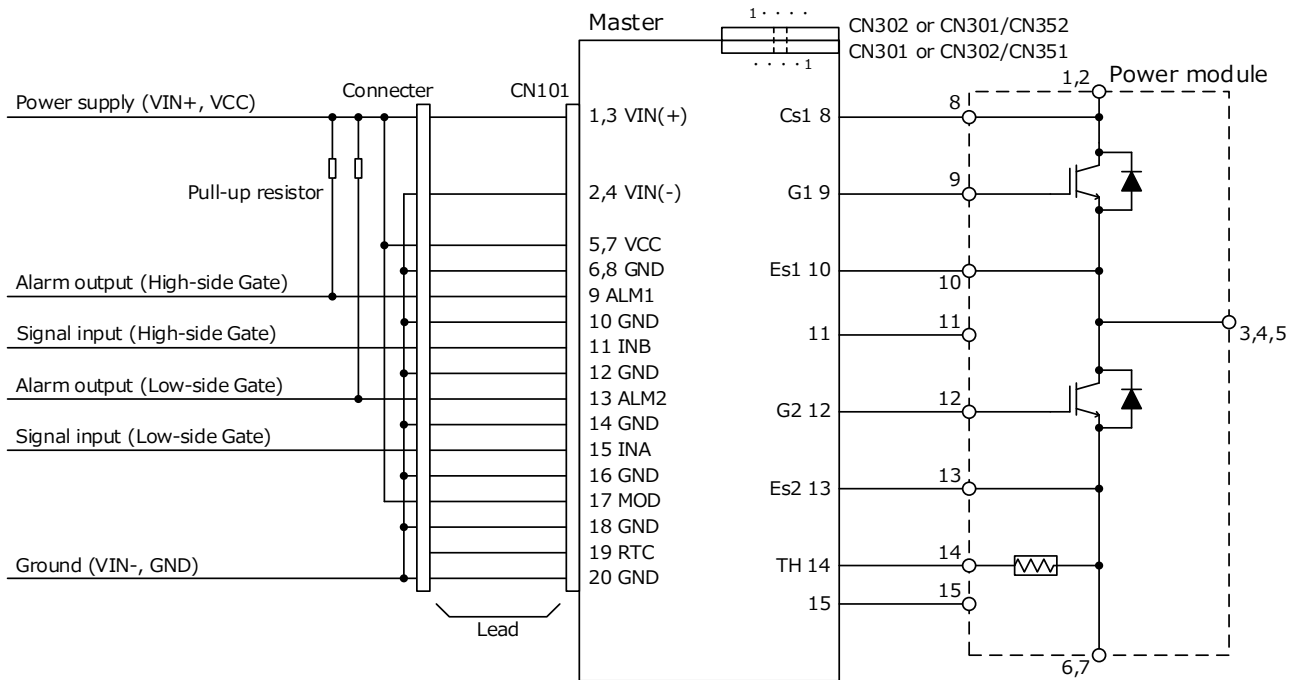

1.2 Half bridge mode / No thermistor isolated amplifier output function

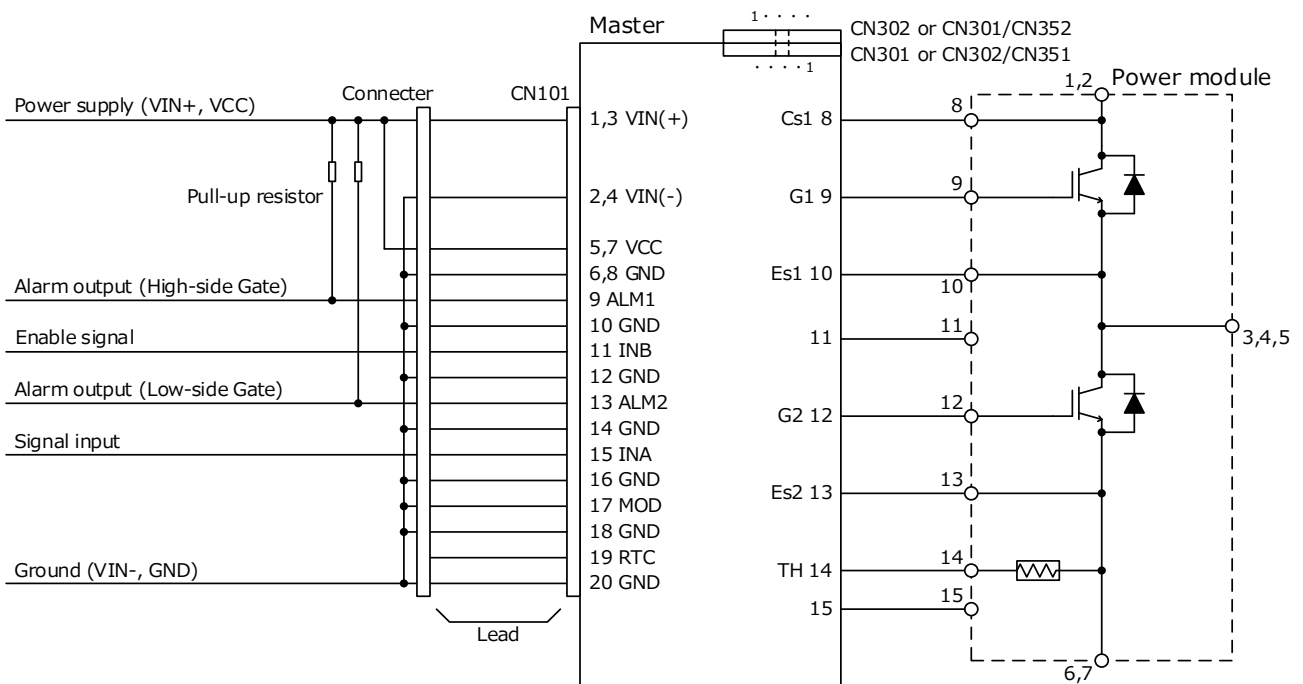

1.3 Direct mode / With thermistor isolated amplifier output function

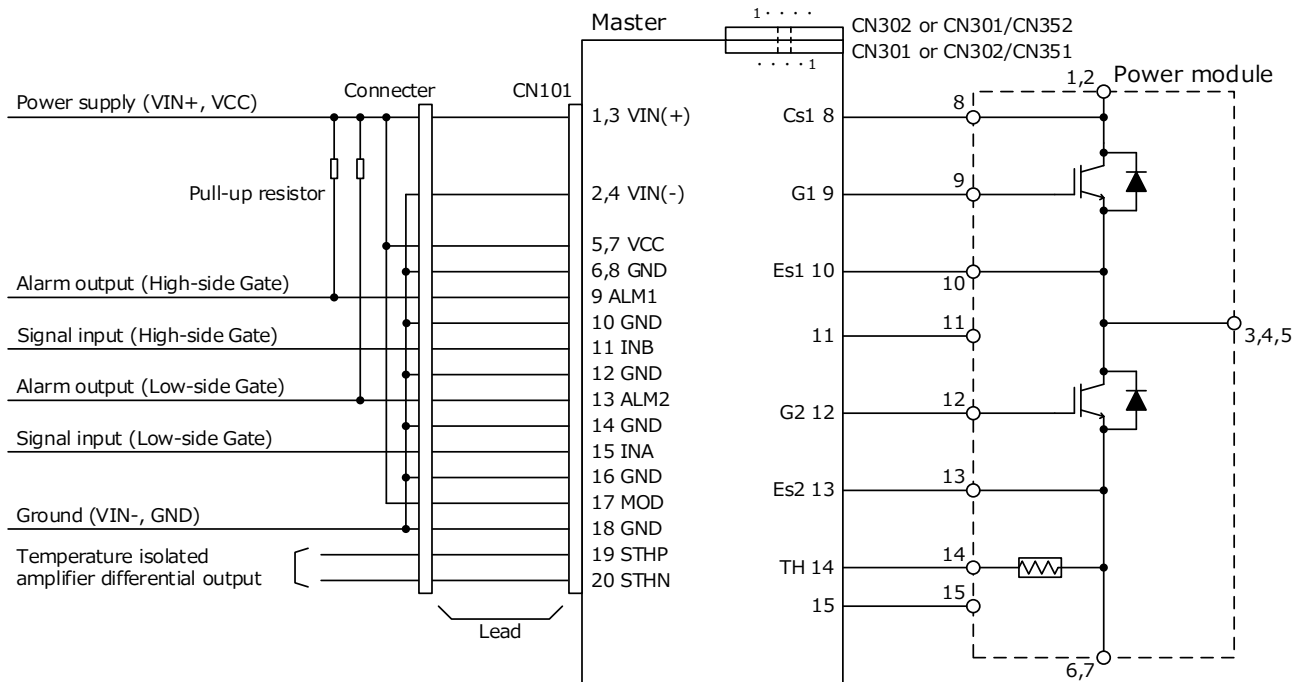

1.4 Half bridge mode / With thermistor isolated amplifier output function

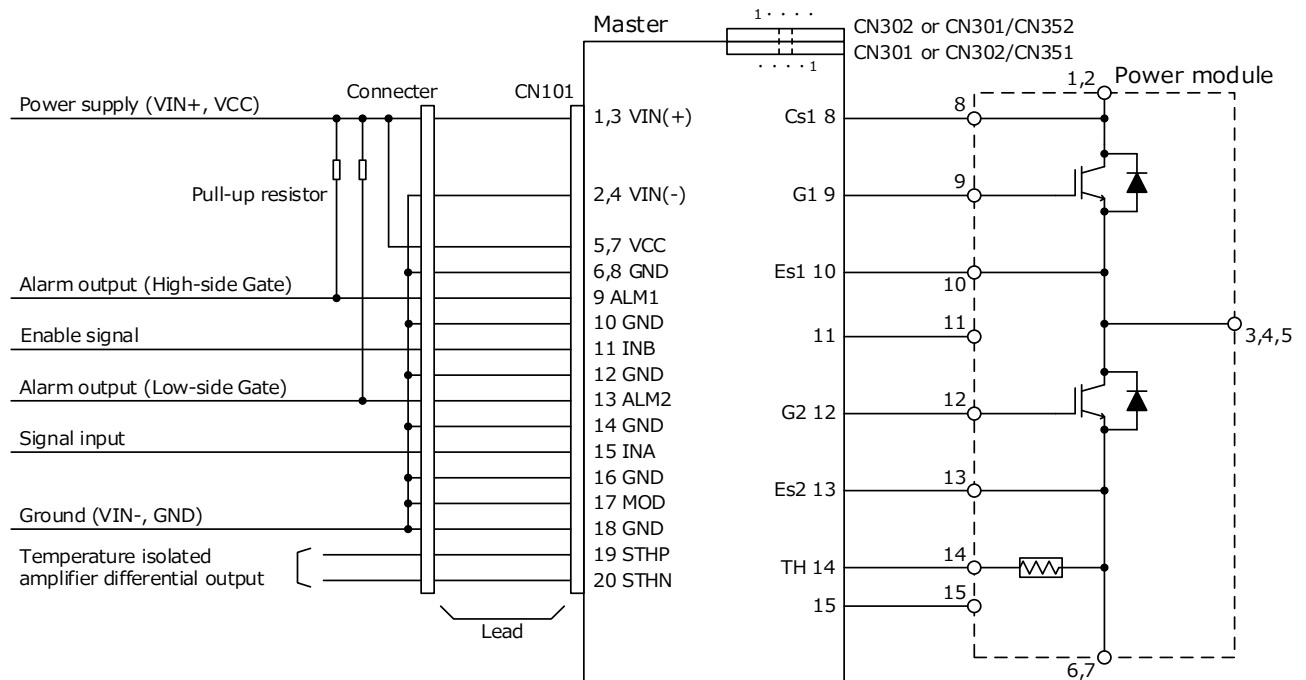

1.5 Direct mode / With thermistor PWM output function

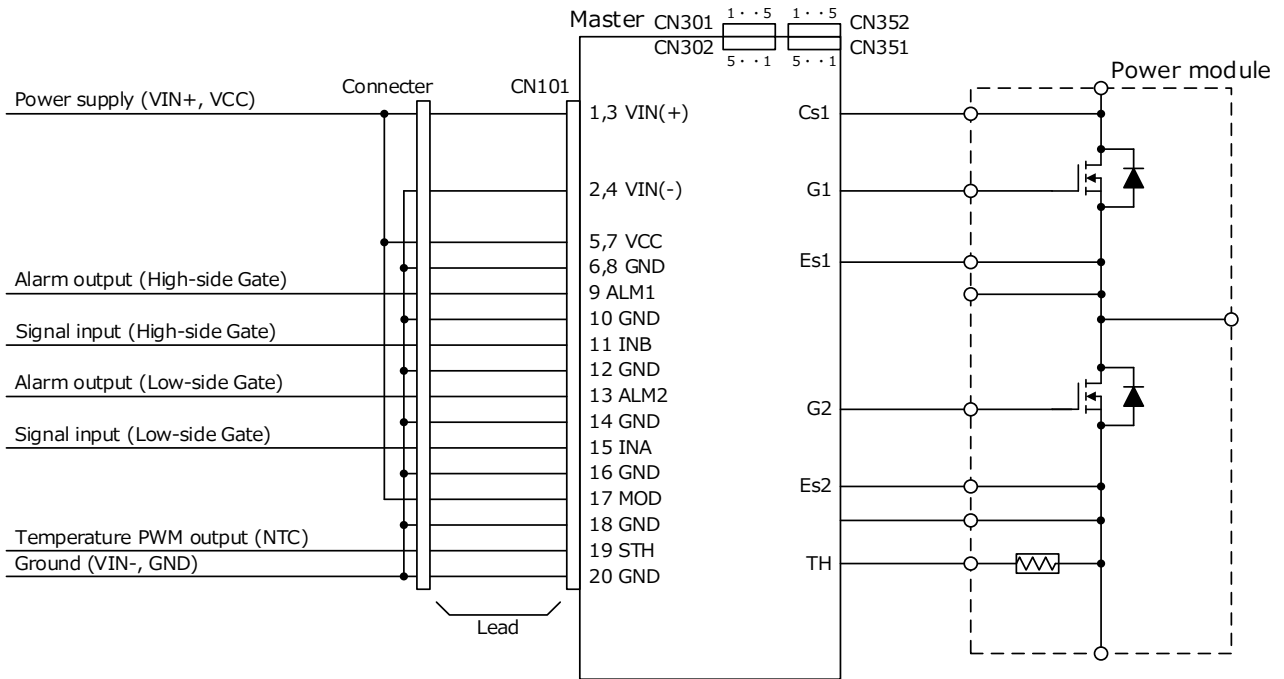

1.6 Half bridge mode / With thermistor PWM output function

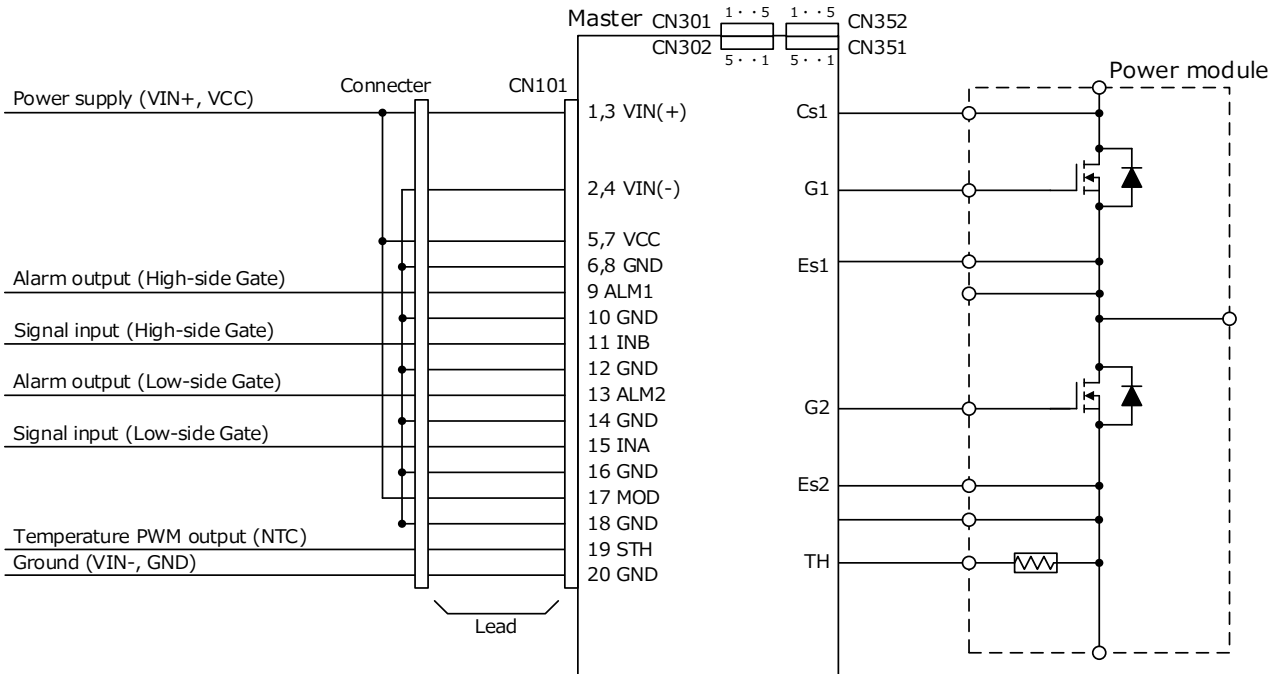

2. Pin Functions and Descriptions

2.1 Pin Functions

(1) VIN(+), VIN(-) (Power supply pin for DC/DC converter)

(2) VCC (Power supply pin for drive circuit)

(3) GND (Ground pin for drive circuit)

(4) MOD, INA, INB (Mode switching pin, Control input pin)

The INA, INB and MOD pin is a pin used to determine output logic.

Direct mode / Half bridge mode can be switched by MOD pin.

In Half bridge mode, it functions as INA: gate signal, INB: enable signal.

At start up, please INA and INB pin is Low.

MOD	INB	INA	G1(H)	G2(L)	Mode
H (Floating or Connected to VCC)	X	L	X	L	Direct mode
	X	H	X	H	
	L	X	L	X	
	H	X	H	X	
L (Connected to GND)	L	X	L	L	Half bridge mode
	H	L	H	L	
	H	H	L	H	

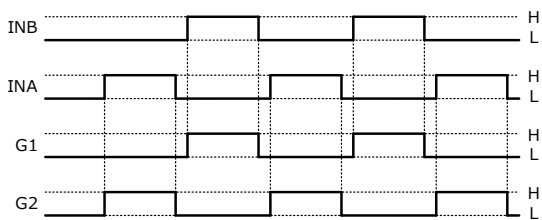

Timing chart of Direct mode

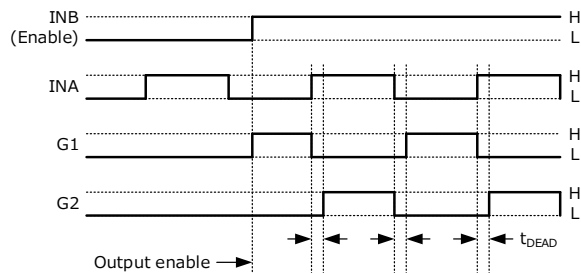

Timing chart of Half bridge mode

(5) ALM1,2 (Alarm signal output pin)

When abnormality occurs (UVLO, short circuit detected), This pin outputs an alarm signal. (Open drain)

Status	ALM1,2
While in normal operation	Hi-Z
UVLO, When detecting short circuit, When Gate-Emitter short circuit	L

When using this function, connect a pull-up resistor because it is an open drain output.

Pull-up voltage [V]	Pull-up resistor [kΩ]
5	4.7
15	15

(6) RTC (Restart time of protection circuit control pin)

The RTC pin can be used to adjust the restart time from the protected state (UVLO, short circuit detection).

When this pin is open, the restart time is set to 110ms(typ).

The restart time can be adjusted within the following range by the resistance or voltage connected to the RTC pin.

① Adjustment by resistor

The restart time can be adjusted by adding a resistor between RTC and GND.

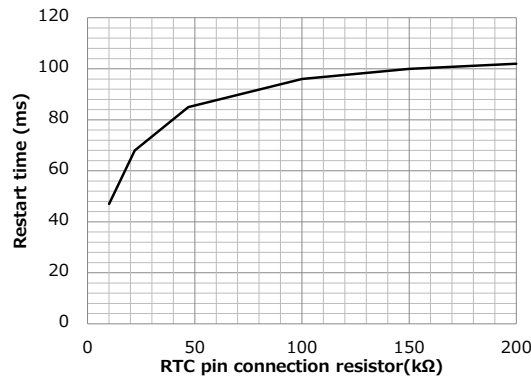
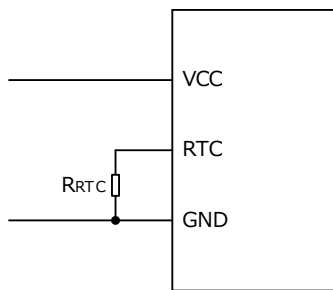

② Adjustment by voltage

The restart time can be adjusted by applying a voltage between RTC and GND.

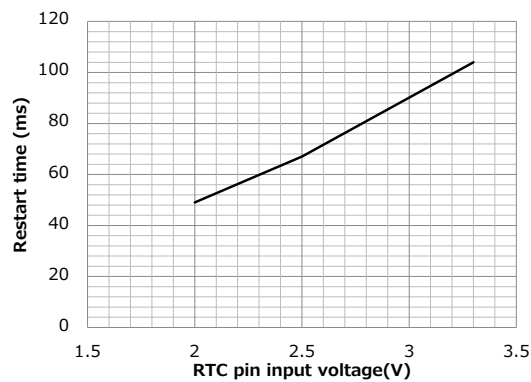
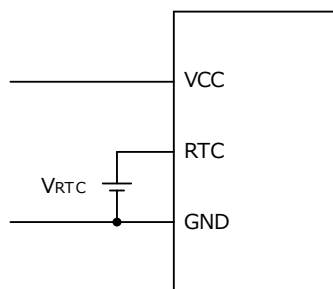

(7) STHP, STHN (Output pins of the thermistor isolated amplifier)

This is the output pins of the thermistor insulation amplifier.

Differential output (analog) of STHP pin and STHN pin.

(8) STH (Output pins of the thermistor PWM signal)

This is the PWM signal output terminal for the thermistor.

This is a PWM output whose duty cycle changes depending on the resistance of the thermistor.

2.2 Description

(1) Overload protection function (DC / DC converter)

The overload protection function is protection when an output short circuit or overload occurs.

The operation mode is automatic reset operation.

Do not use beyond the maximum output power or permissible frequency curve as it may cause the gate voltage to drop.

(2) Overheat protection (DC / DC converter)

This module has an overheat protection function to prevent damage and smoke even if the module overheats for some reason.

The operation mode is automatic reset operation.

Operation is auto restored when the internal temperature of the module becomes normal.

(3) Undervoltage Lockout (UVLO) function

The control circuit incorporates the undervoltage lockout (UVLO) function on the OUT(H) sides.

When the OUT(H) voltage drops to the UVLO ON voltage, the Output pin and the ALM pin both will output the "L" signal.

When the OUT(H) voltage rises to the UVLO OFF voltage, these pins will be reset.

(4) Short circuit protection function, Soft turn-off function

When the collector pin voltage exceeds V_{SD} , the short circuit protection function will be activated.

When the short circuit protection function is activated, the OUT pin voltage will be set to the "L" level, and then the ALM pin voltage to the "L" level.

Also, soft turn-off function works to reduce collector voltage surge due to short circuit current.

Short-circuit protection is canceled automatically after an abnormal condition restart time and when the input signal is "L" level.

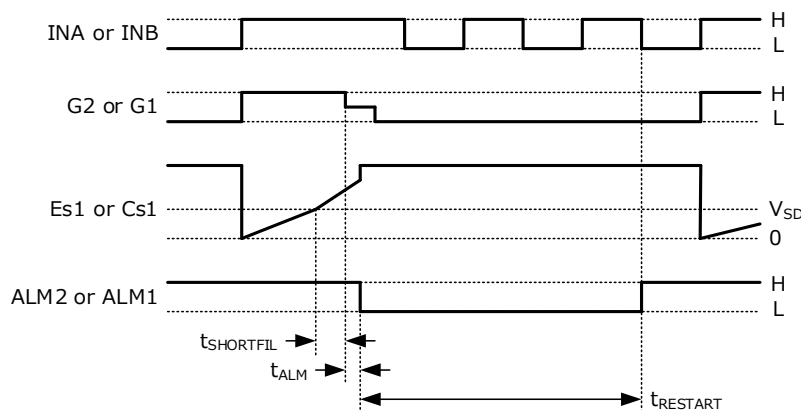

Timing chart of short circuit protection function

(5) Active clamp function (Option)

The active clamp function protects the IGBT from a sudden voltage surge between the collector and emitter that occurs when the IGBT is turned off. Depending on the DC-LINK voltage and surge voltage, the losses that occur in TVS diodes and IGBTs increase. If a high surge voltage is clamped continuously, stress will be applied to the driver and IGBT. Therefore, the main circuit conditions (DC-LINK voltage, parasitic inductance, dI_c / dt) should be optimized and designed so that the active clamp function does not operate in normal status. Design the TVS surface temperature not to exceed 120 °C under any conditions.

When the collector-gate voltage exceeds the breakdown voltage of the active clamp TVS diode, current flows from the collector to the gate. The current (I_{tvs}) supplies the gate with charge, partially turning on the IGBT and clamping the collector voltage. TVS loss can be obtained by time integration of the current (I_{tvs}) and collector-emitter voltage (V_{ce}).

To strengthen the clamp, the gate may rise even during the period when no current is flowing through the TVS diode, but this is not a malfunction.

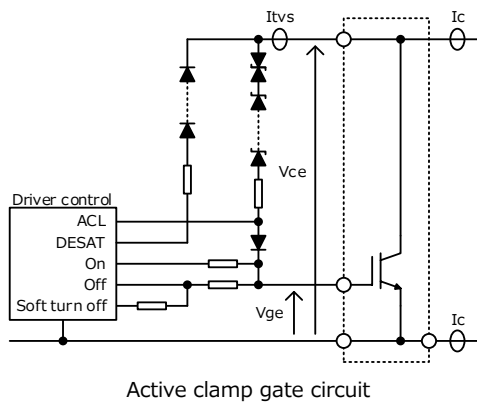

Active clamp gate circuit

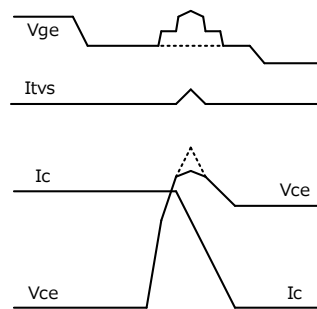

Timing chart of Active clamp function

3. Product Connection Instructions, Ambient Environment Instructions, Usage Cautions

3.1 Abnormal input current protection

Always mount fuse on the plus side of input for ensuring safety because the fuse is not built-in the product.
 Please select the fuse considering conditions such as steady current, inrush current, and ambient temperature.
 When using a fuse having large rated current or high capacity input electrolytic condenser, by combining another converter and input line and input electrolytic condenser, fuse may not blow off in the case of abnormality.
 Do not combine high voltage line and fuse.

3.2 VIN- and GND

Although VIN- and GND are insulated inside the product, they are not designed to be insulated according to safety standards.
 Connect on the set side so that there is no electric potential difference between VIN- and GND.

3.3 Power ON / OFF sequence (VIN+, VCC)

There is no need to consider the power ON / OFF sequence for VIN + and VCC.
 Since you can input from the common power supply, you can unify the power supply lines.
 Also, be careful not to turn the signal voltage on when VCC is off, as there is a protection diode between VCC and the signal line.

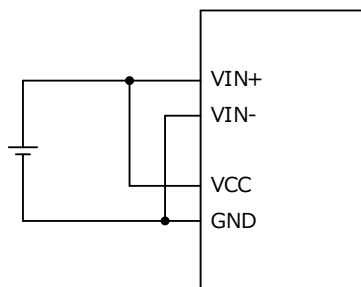

3.4 Mechanical switch

Do not connect mechanical switches to the input line.
 If a mechanical switch is required, add a rush-prevention resistor in series with the mechanical switch.

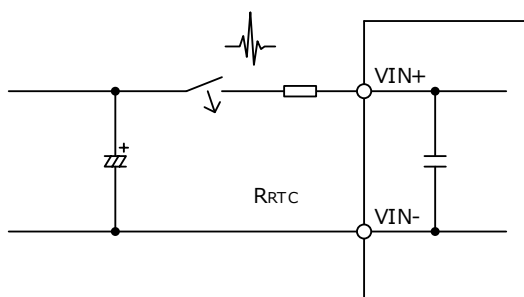

3.5 Input signals

Make sure the rise/fall time of the input signal is 500ns or less.

Also, keep input wiring as far as possible from noise sources.

To prevent malfunction due to noise, we recommend the highest possible signal voltage within the recommended range.

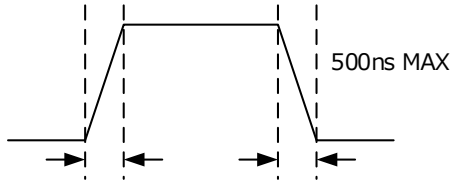

3.6 Input cables

Bringing the input cable of the product closer to the main circuit side will cause malfunction due to conduction noise and magnetic flux noise on the main circuit side. Therefore, place the input cable far from where these noises are likely to occur.

If the input cable of the product and the main circuit are close to each other due to space restrictions, we recommend changing the cable to be used to a ribbon cable (stranded wire type) or adding a ferrite core, or both.

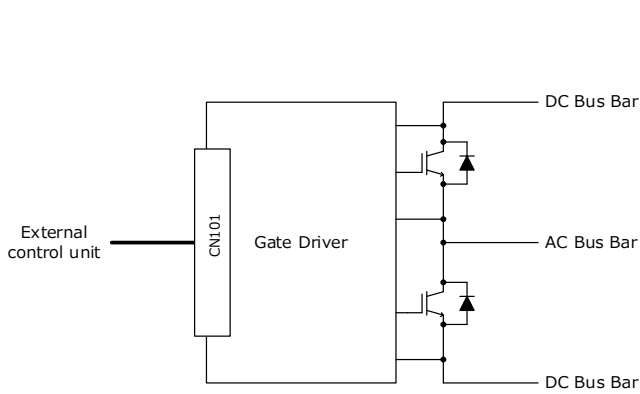

OK example

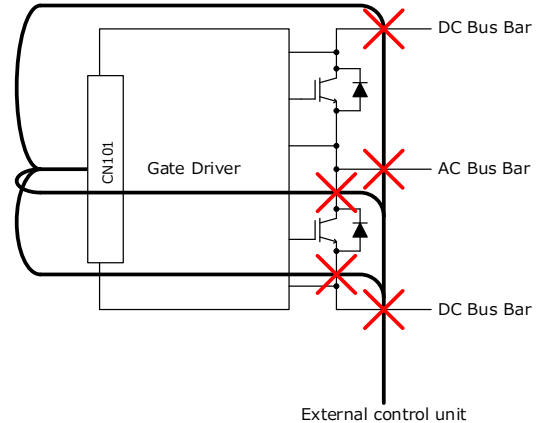

NG example

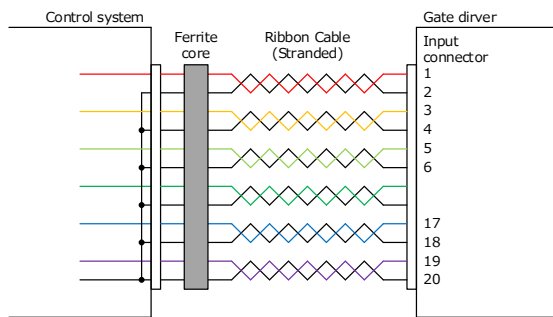

Input cables

3.7 Half bridge mode

The dead time set in half bridge mode is not highly accurate because it is set by the time constant of the capacitor and resistor.

Select direct mode if more accurate operation is required.

3.8 Product mounting instructions

Please do not apply excessive stress to this product when attaching to IGBT power module.

Please follow the device manufacturer's instructions on how to install the IGBT power module

(type of screw used, material, tightening torque conditions, etc.).

Also, the screw header / washer diameter uses the following.

- M3 (Printed circuit board fixed) : 6mm or less *

*To maintain the reliability of parts near the metal terminal pad,

the screw header including the washer must not exceed the available metal terminal pad of the gate driver.

3.9 Handling

When handling, do not apply excessive stress to this product.

Do not handle or touch the product in an environment without ESD protection, as it may cause product failure and affect reliability.

3.10 IGBT/SiC MOSEFT short circuit

This product has DESAT protection for arm short circuit and load short circuit protection.

However, even if this protection works, the IGBT/SiC MOSFET device may be damaged if abnormally high current occurs due to device's characteristics variations or the load short-circuit mode during parallel operation.

To ensure safety, be sure to check the short-circuit current at the unit in which this product is integrated, and evaluate whether it can protect under the condition that there is no damage to the device.

3.11 Ambient temperature instructions

The operating ambient temperature of the gate driver should be the temperature inside the set, and measure it as follows.

If heat is generated from a peripheral component, the temperature of the heat should be regarded as the ambient temperature.

If there is no heat-generating component around the gate driver, the temperature at a point that is 20 mm above the center of the gate driver case should be regarded as the ambient temperature.

Use according to the permissible frequency curve described in the data sheet for each product.

Use the gate driver board with a maximum surface temperature of 120 °C or less.

<Point where the ambient temperature is measured if there is a heat-generating component near the module>

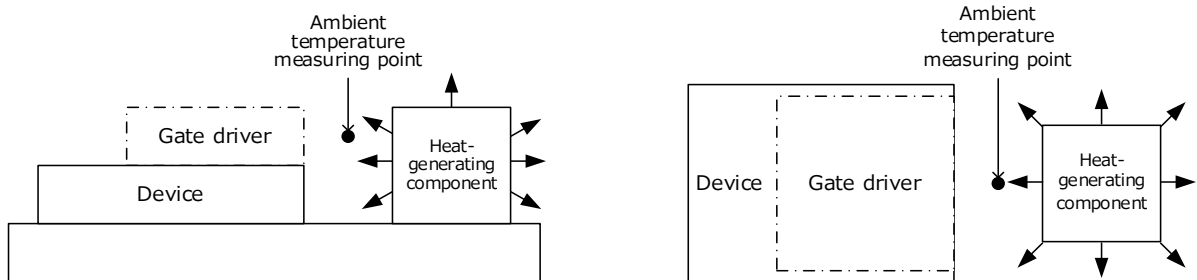

<Point where the ambient temperature is measured if there are no effects of heat-generating components>

