

<b>Gate Driver Slave Unit 2LG02xCZC11S</b>
--

**■ Overview**

2LG02xCZC11S is a parallel drive slave unit used by connecting to 2LG02xxxC11M.  
 IGBT power modules are compatible with CM1200DW-24T .  
 This document is the data sheet of the slave unit.  
 Please refer to the data sheet: 2LG02xCZC11M for the master unit.

**■ Features**

- Ideal for drive of IGBT Power module CM1200DW-24T(Mitsubishi Electric)
- Ideal for parallel drive by using with 2LG02xCZC11S
- Gate voltage : +15V/-10V
- Gate resistor : +1.2Ω/-4.7Ω(TYP)
- Soft turn-off function (Gate drive circuit)
- Under-voltage lockout(UVLO) (Gate drive circuit)
- Thermistor isolated amplifier output function (Option)
- Insulating moistureproof coating

**■ Application**

Industrial inverter, power conditioner, etc. ...

**■ Module information**

Part number	Part number (Uncoated)	Signal input voltage	Active clamp	TH Isolated amplifier	Status
2LG02CZC11S	2LG02CZN11S	-	None	None	Planning
2LG02ACZC11S	2LG02ACZN11S	-	None	Yes	Active

\*Uncoated type is sample only

\*Refer to the [2LG02xCx11M] data sheet for master units.

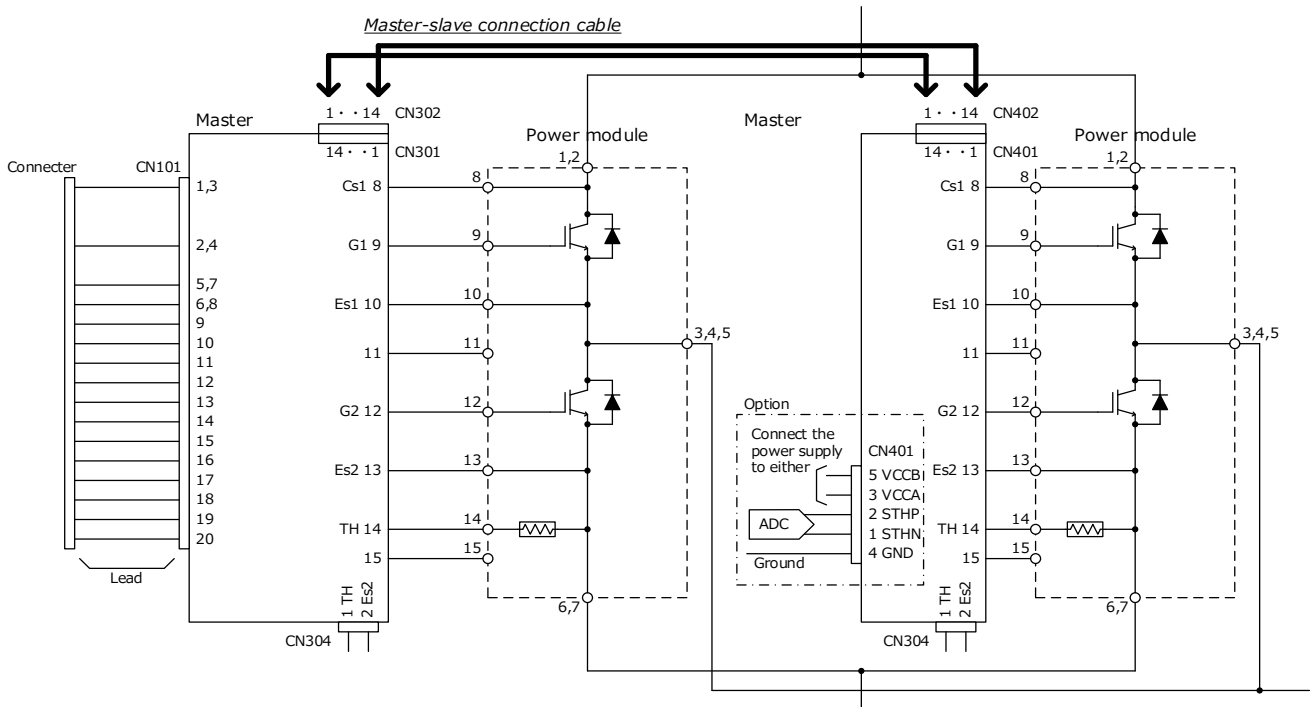
**■ Circuit Image**

**■ Pin Connection**

CN401 : B10(14-6.7.8.9)B-PASK(LF)(SN) (JST)

Pin No.	Name	CH	Function
1	CC1A1	1	Connect the communication line for parallel drive 2LG series
2	CC1A2	1	
3	CC1A3	1	
4	CC1A4	1	
5	CC1A5	1	
6	None	-	Pin removal for insulation distance between CH1 and CH2
7	None	-	
8	None	-	
9	None	-	Connect the communication line for parallel drive 2LG series
10	CC2A5	2	
11	CC2A4	2	
12	CC2A3	2	
13	CC2A2	2	
14	CC2A1	2	

※Reference receptacle : PAP-14V-S (JST)

CN402 : B10(14-6.7.8.9)B-PASK(LF)(SN) (JST)

Pin No.	Name	CH	Function
1	CC2B1	2	Connect the communication line for parallel drive 2LG series
2	CC2B2	2	
3	CC2B3	2	
4	CC2B4	2	
5	CC2B5	2	
6	None	-	Pin removal for insulation distance between CH1 and CH2
7	None	-	
8	None	-	
9	None	-	Connect the communication line for parallel drive 2LG series
10	CC1B5	1	
11	CC1B4	1	
12	CC1B3	1	
13	CC1B2	1	
14	CC1B1	1	

※Reference receptacle : PAP-14V-S (JST)

Connection on the power module

No.	Name	CH	Function	No.	Name	CH	Function
8	Cs1	1(H)	Collector connection, High side	12	G2	2(L)	Gate connection, Low side
9	G1	1(H)	Gate connection, High side	13	Es2	2(L)	Emitter connection, Low side
10	Es1	1(H)	Emitter connection, High side	14	TH	2(L)	Thermistor connection, Low side
11	None	-	Electrical connection is not allowed	15	None	-	Electrical connection is not allowed

■ Pin Connection (With thermistor isolated amplifier output function)

CN401 : B05B-PASK (JST)

No.	Name	Function
1	STHN	Inverting analog output of the isolated amplifier
2	STHP	Noninverting analog output of the isolated amplifier
3	VCCA	Power supply for isolated amplifier (5VDC)
4	GND	Ground for isolated amplifier
5	VCCB	Power supply for isolated amplifier (15VDC)

\*Connect this power supply to either VCCA (5VDC) or VCCB (15VDC).

\*Connect this power supply to either VCCA (5VDC) or VCCB (15VDC).

※Reference receptacle : PAP-05V-S (JST)

■ Internal Block Diagram

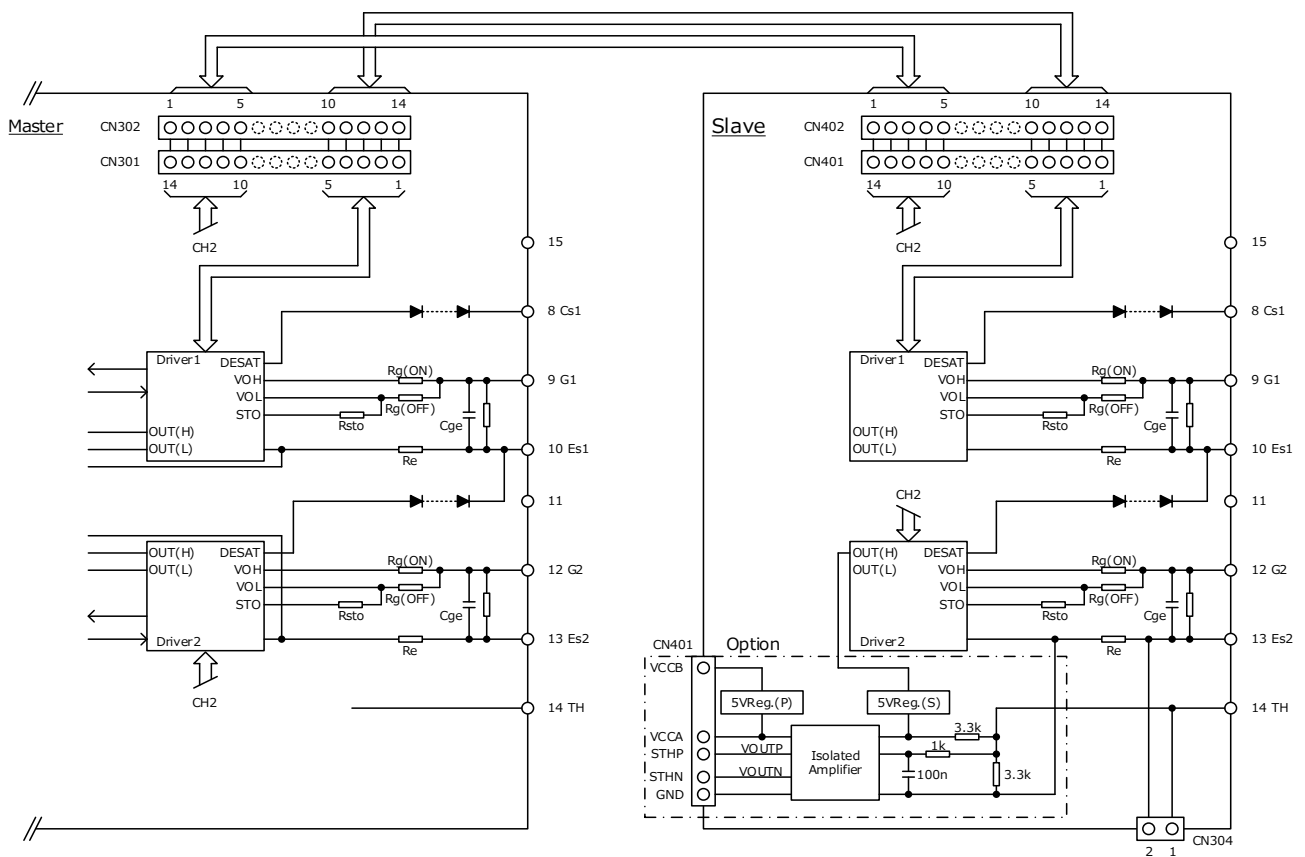

■ Master-slave connection diagram

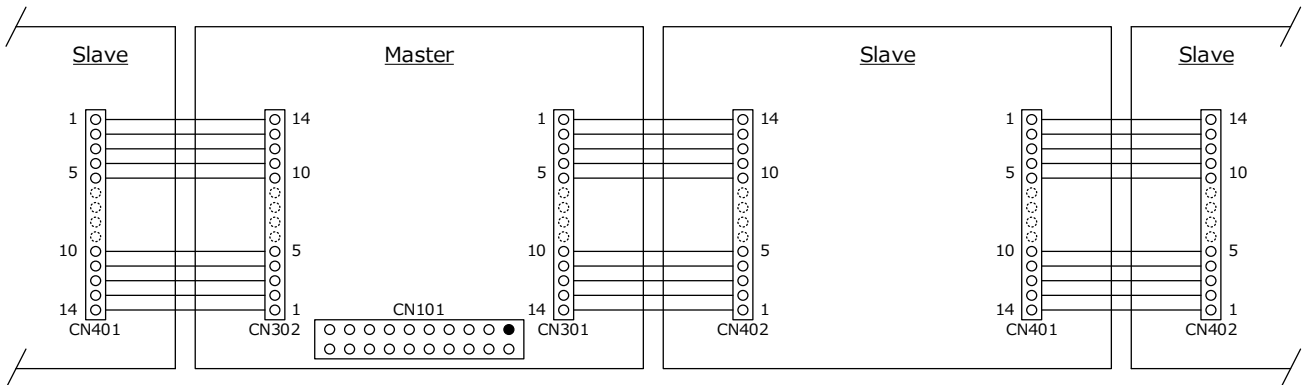

■ Master-slave connection cable example

\*This sample is provided with cable.

\*You must meet the required wire standard according to the usage conditions.

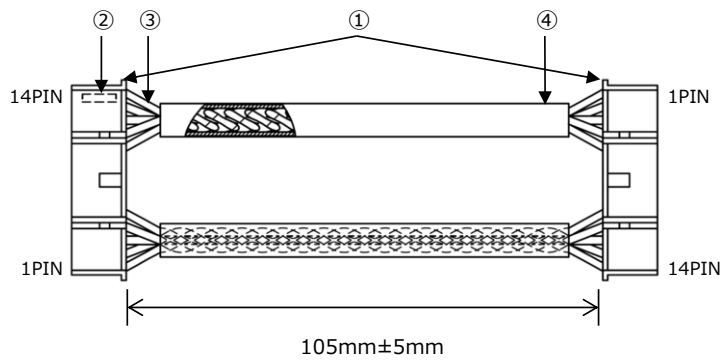

No.	Name	Part No,	Quantity	Manufacturer
②	Contact	SPHD-001T-P0.5	20	JST
①	Housing	PAP-14V-S	2	JST
③	Wire	AWG#24(UL3443) *Twist processing	10	-
④	Tube	SUMITUBE F2(Z)	2	SUMITOMO

**■ Absolute Maximum Ratings**

Item	Symbol	Min	Max	Unit	Conditions · Note
Maximum gate current	$I_{GPEAK}$	-	43	A	Excluding gate resistor
Short circuit detection pin voltage	$V_{SD}$	0	1200	V	
Operating temperature range	$T_{OP}$	-40	85	°C	See the derating curve
Operating humidity	$RH_{OP}$	20	95	%RH	No condensation
Storage temperature range	$T_{STG}$	-40	90	°C	
Storage humidity	$RH_{STG}$	5	95	%RH	No condensation
With thermistor isolated amplifier output function					
Input voltage of isolated amplifier (VCCA)	$V_{STHI}$	-0.3	5.5	V	Between VCCA to GND *1
Input voltage of isolated amplifier (VCCB)	$V_{STHI}$	-0.3	18	V	Between VCCB to GND *1
Output voltage of isolated amplifier	$V_{STHO}$	-0.3	5.3	V	STHP, STHN

\*1 Connect this power supply to either VCCA (5VDC) or VCCB (15VDC).

**■ Recommended Operating Conditions**

Item	Symbol	Min	Max	Unit	Conditions · Note
Driver circuit number	N	-	2	-	
Maximum gate charge	$Q_G$	-	14000	nC	*2
Switching frequency	$F_{SW}$	-	2.8	kHz	Test load : 0.33Ω/560nF See the Operating frequency in parallel graph
With thermistor isolated amplifier output function					
Input voltage of isolated amplifier (VCCA)	$V_{STHI}$	4.8	5.2	V	Between VCCA to GND *3
Input voltage of isolated amplifier (VCCB)	$V_{STHI}$	13.5	18	V	Between VCCB to GND *3

\*2 If the gate charge exceeds the allowable value, the gate voltage at turn-on and turn-off will drop, which may affect the switching performance of the device.

If you are considering using it under conditions other than the recommended conditions, please contact us.

\*3 Connect this power supply to either VCCA (5VDC) or VCCB (15VDC).

**■ Operating frequency in parallel**

Reference value

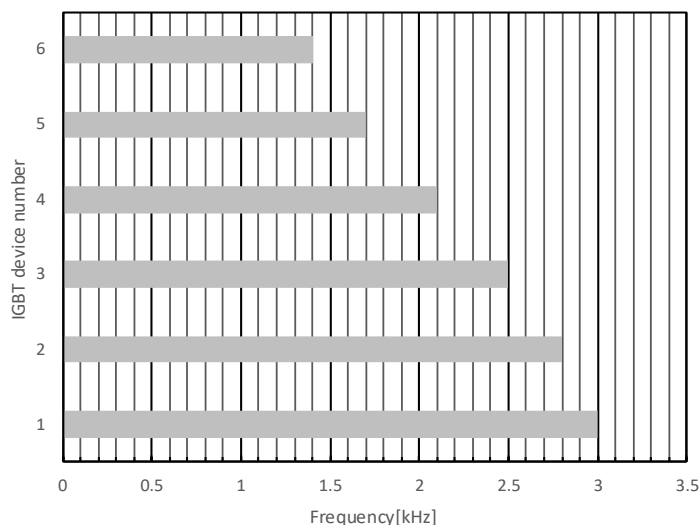

Test load : 0.33Ω/560nF  
Rg: +1.2ohm/-4.7ohm

■ Electrical Specification (Ta=25°C, Unless otherwise specified)

Item	Symbol	Min	Typ	Max	Unit	Conditions · Note	
Gate driver output							
Output pin voltage(High)	V <sub>OUTH</sub>	14	15	16	V	No load	
Output pin voltage(Low)	V <sub>OUTL</sub>	-11	-10	-9	V	No load	
Gate resistor	Rg(ON)	-	1.2	-	Ω		
	Rg(OFF)	-	4.7	-			
Auxiliary gate capacitor	Cge	-	10	-	nF		
Emitter resistor	Re	-	0.1	-	Ω		
2LG01AxZx11S (With thermistor isolated amplifier output function)							
Thermistor signal output voltage	TH = 5000Ω	V <sub>STHP-N</sub>	-	1.88	-	V	STHP-STHN
	TH = 300Ω		-	0.39	-	V	

■ Thermistor Signal Output Voltage Curve (With thermistor isolated amplifier output function)

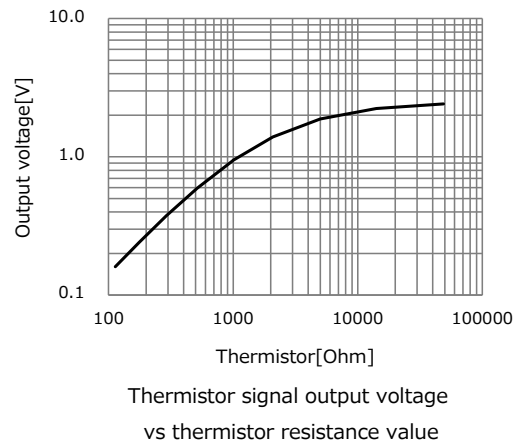
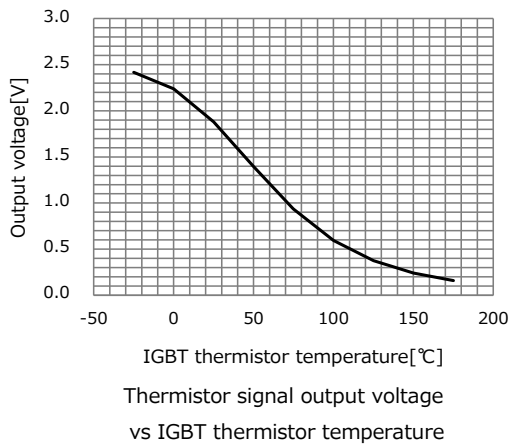

■ Protection

Item	Symbol	Min	Typ	Max	Unit	Conditions · Note
Gate driver						
Soft turn-off resistance	R <sub>STO</sub>	-	7.5	-	Ω	
Soft turn-off duration	t <sub>STO</sub>	-	6	-	us	

**■ Insulation**

Item	Specification	Conditions · Note
Between CH1-CH2		
Minimum clearance distances	8mm	Excluding electrical connections point
Minimum creepage distances	8mm	
Between Input-Thermistor (With thermistor isolated amplifier output function)		
Dielectric withstand voltage	AC5000V	1min, Cutoff 2mA
Insulation resistance	100MΩ or more	DC500V
Partial discharge extinction voltage	1875Vpeak or more	According to EN50178/IEC 60270
Minimum clearance distances	8.5mm	
Minimum creepage distances	8.5mm	

**■ Storage Conditions**

Item	Min	Max	Unit	Conditions · Note
Storage temperature	-25	60	°C	A packing state

**■ Usage Cautions**

- Please do not apply excessive stress to this product when attaching to IGBT power module.

Please follow the device manufacturer's instructions on how to install the IGBT power module (type of screw used, material, tightening torque conditions, etc.).

Also, The screw header / washer diameter uses the following.

M3: 6mm or less

\*To maintain the reliability of parts near the metal terminal pad, the screw header including the washer must not exceed the available metal terminal pad of the gate driver.

- The coating material is applied to the product, so it may appear to be partially whitened.

This does not affect the characteristics of the product.

With Thermistor insulation circuit

## ■ Outline Dimensional Drawing

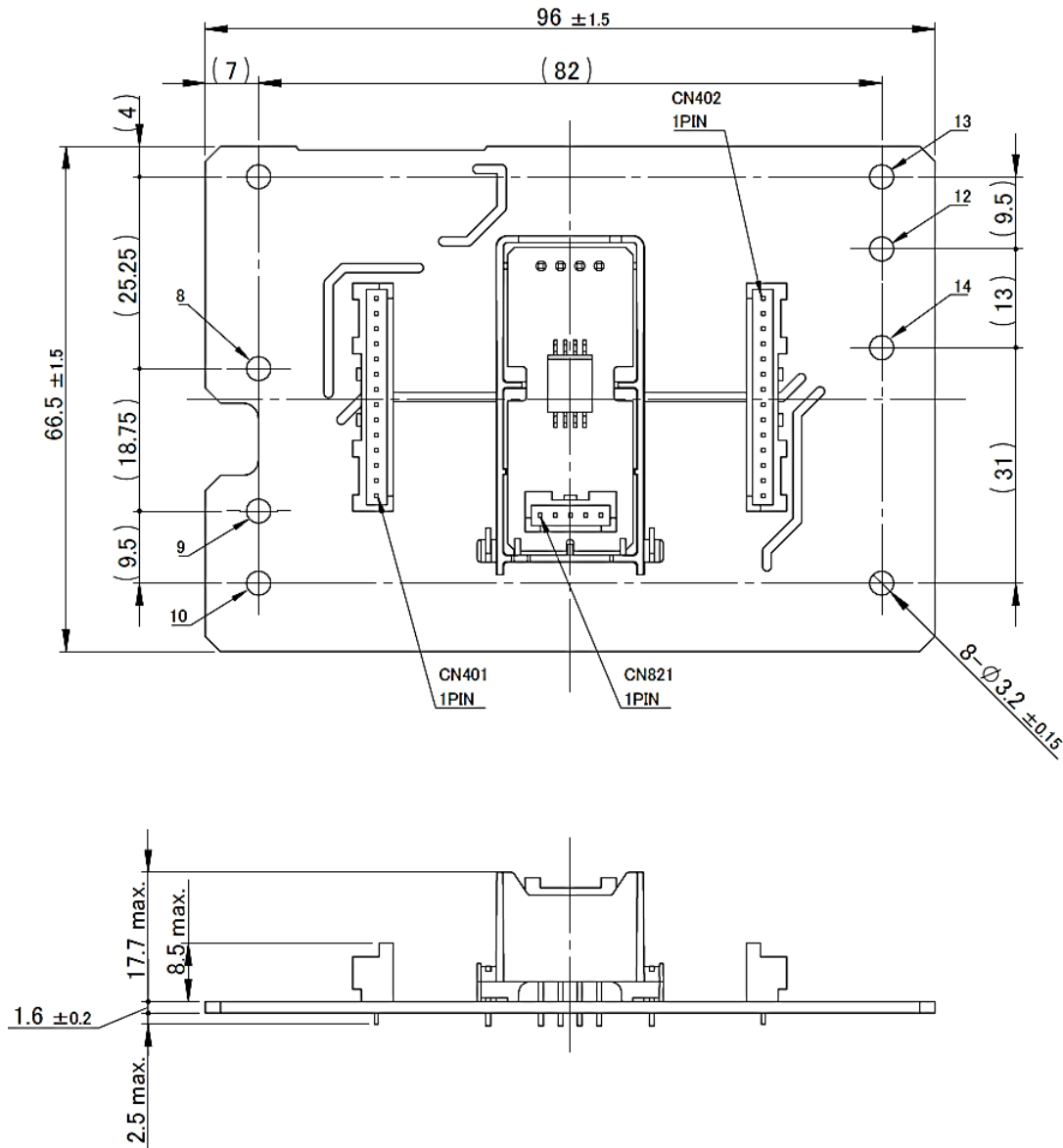

Unit: mm

Note: 1. The dimensional tolerance without directions is  $\pm 0.5$ mm.

## ■ Product Weight

30.5g(typ)

Without Thermistor insulation circuit

## ■ Outline Dimensional Drawing

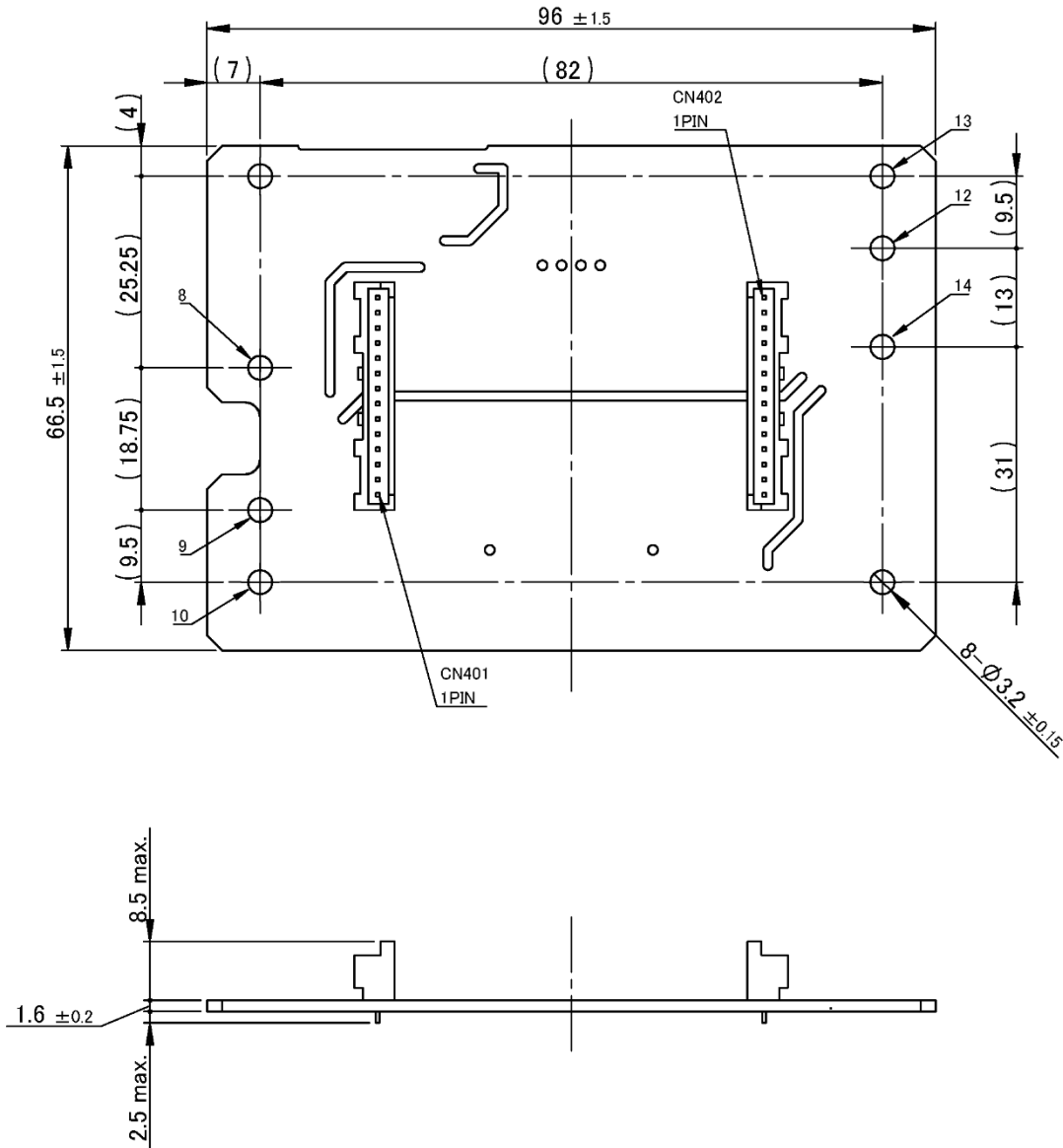

Unit: mm

Note: 1. The dimensional tolerance without directions is  $\pm 0.5$ mm.

## ■ Product Weight

25.0g(typ)

### ■ Important Notice

- This information and product are subject to change without prior notice for the purpose of improvements, etc.  
Ensure that you are in possession of the most up-to-date information when using this product.
- The operation examples and circuit examples shown in this document are for reference purposes only, and TAMURA Corporation disclaims all responsibility for any violations of industrial property rights, intellectual property rights and any other rights owned by TAMURA Corporation or third parties that these may entail.
- The circuit examples and part constants listed in this document are provided as reference for the verification of characteristics. You are to perform design, verification, and judgment at your own responsibility, taking into account the various conditions.
- TAMURA has evaluated the efficiency and performance of this product in a usage environment determined by us.  
Depending on your usage environment or usage method, there is the possibility that this product will not perform sufficiently as shown in the specifications, or may malfunction.  
When applying this product to your devices or systems, please ensure that you conduct evaluations of their state when integrated with this product. You are responsible for judging its applicability.  
TAMURA bears no responsibility whatsoever for any problems with your devices, systems or this product which are caused by your usage environment or usage method.
- TAMURA Corporation constantly strives to improve quality and reliability, but malfunction or failures are bound to occur with some probability in power products. To ensure that failures do not cause accidents resulting in injury or death, fire accidents, social damage, and so on, you are to thoroughly verify the safety of their designs in devices and/or systems, at your own responsibility.
- This product is intended for use in consumer electronics (electric home appliances, business equipment, Information equipment, communication terminal equipment, measuring devices, and so on.) If considering use of this product in equipment or devices that require high reliability (medical devices, transportation equipment, traffic signal control equipment, fire and crime prevention equipment, aeronautics and space devices, nuclear power control, fuel control, in-vehicle equipment, safety devices, and so on), please consult a TAMURA sales representative in advance. Do not use this product for such applications without written permission from TAMURA Corporation.
- This product is intended for use in environments where consumer electronics are commonly used.  
It is not designed for use in special environments such as listed below, and if such use is considered, you are to perform thorough safety and reliability checks at your own responsibility.
  - Use in liquids such as water, oil, chemical solutions, or organic solvents, and use in locations where the product will be exposed to such liquids.
  - Use that involves exposure to direct sunlight, outdoor exposure, or dusty conditions.
  - Use in locations where corrosive gases such as salt air, C12, H2S, NH3, SO2, or NO2, are present.
  - Use in environments with strong static electricity or electromagnetic radiation.
  - Use that involves placing inflammable material next to the product.
  - Use of this product either sealed with a resin filling or coated with resin.
  - Use of water or a water soluble detergent for flux cleaning.
  - Use in locations where condensation is liable to occur.
- This product is not designed to resist radiation.
- Do not use or otherwise make available the TAMURA products or the technology described in this document for any military purposes, including without limitation, for the design, development, use, stockpiling or manufacturing of mass destruction weapons (e.g. nuclear, chemical, or biological weapons or missile technology products).  
When exporting and re-exporting the products or technology described in this document, you should comply with the applicable export control laws and regulations and follow the procedures required by such laws and regulations including, without limitation, Japan -Foreign Exchange and Foreign Trade Control Law and U.S.- Export Administration Regulations.  
The TAMURA products and related technology should not be used for or incorporated into any products or systems whose manufacture, use, or sale is prohibited under any applicable domestic or foreign laws or regulations.
- Please contact your TAMURA sales office for details as to environmental matters such as the RoHS compatibility of product.  
Please use TAMURA products in compliance with all applicable laws and regulations that regulate the inclusion or use of controlled substances, including without limitation, the EU RoHS Directive.  
TAMURA assumes no liability for damages or losses occurring as a result of your noncompliance with applicable laws and regulations.
- TAMURA assumes no liability for damages or losses incurred by you or third parties as a result of unauthorized use of TAMURA products.
- This document and any information herein may not be reproduced in whole or in part without prior written permission from TAMURA.